

Collider physics: a theoretical perspective

GGI 20th
Anniversary



Giulia Zanderighi
Galileo Galilei Institute,
20th Anniversary ceremony, 16th March 2026



Why is high energy interesting

Higher energy allows to access heavier particles: $E = mc^2$

Particle	Collider / Experiment	Energy (GeV)	Year	Mass (GeV/c ²)
J/ψ	SPEAR	3.1	1974	3.097
Tau (τ)	SLAC/LBL (SPEAR)	4	1975	1.777
Bottomonium (Υ)	Fermilab/Cornell	9.46	1977	9.460
W boson	UA1 / CERN SPS	540	1983	80.379
Z boson	UA1 / CERN SPS	540	1983	91.1876
Top quark	Tevatron	1800	1995	173.0
Higgs boson	LHC (ATLAS/CMS)	7000	2012	125.1

In the last 50 years, every time a new energy frontier was explored, a new particle was found

... but times have changed

With the discovery of the Higgs boson the Standard Model of particle physics is complete

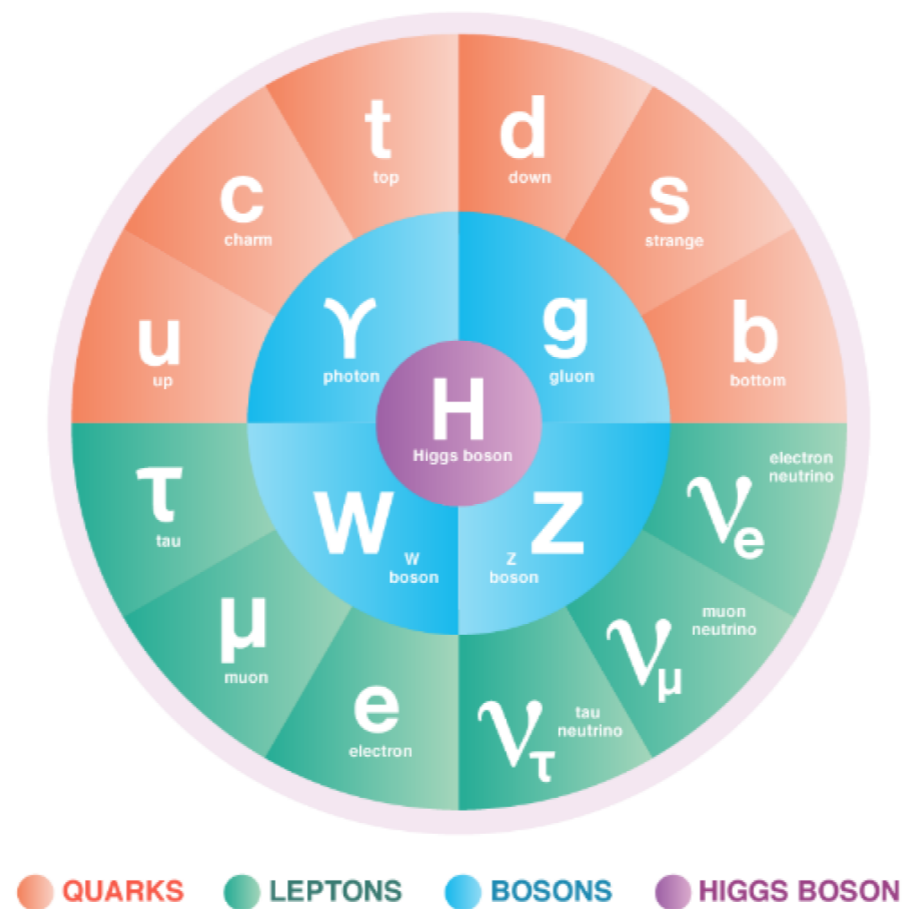

No new discovery can be easily anticipated

Problems ...

Phenomena unaccounted for in the SM

Matter-antimatter asymmetry

Dark matter

Why is $\theta < 10^{-10}$? $\mathcal{L} \supset \theta G_{\mu\nu} \tilde{G}^{\mu\nu}$

Axions?

Accidental symmetries and violations

Proton decay

Parity violation

Lack of calculability/stability

Flavour mass hierarchy

EW hierarchy problem

Structure of the Standard Model (SM)

Why 3 generations?

Why $SU(3) \times SU(2) \times U(1)$?

Observational

Theoretical

TeV-scale new physics?

(As far as I know) The only hint of New Physics at the TeV energy scale comes from the hierarchy problem in the Higgs sector

The argument: *if* there are new particles, that interact in any way with SM particles, they would give rise to corrections to the Higgs mass that depend quadratically on the New Physics scale

BSM



h ———  ——— h

$$\Delta m_h^2 \propto \frac{g_h^2}{16\pi^2} M_{\text{BSM}}^2$$

⇒ Since the Higgs is light, new physics must be around the corner ...

The flavour problem

If there are “light” new physics particles, they would affect many flavour changing decays, oscillation or mixing diagrams

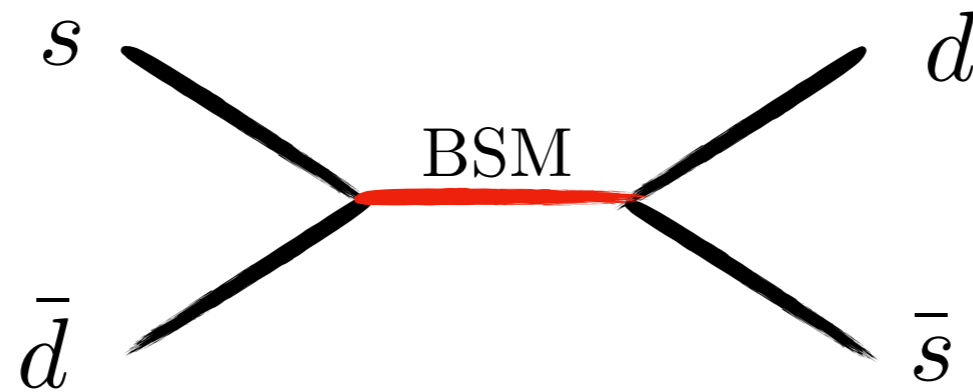

$$\Delta m_K \propto \frac{g_{sd}^2}{M_{\text{BSM}}^2}$$

☞ No effects in flavour physics suggests BSM must be **heavy**

The Higgs & flavour tension

Tension between hierarchy problem in the Higgs section and absence of New Physics in the flavour sector is a major puzzle

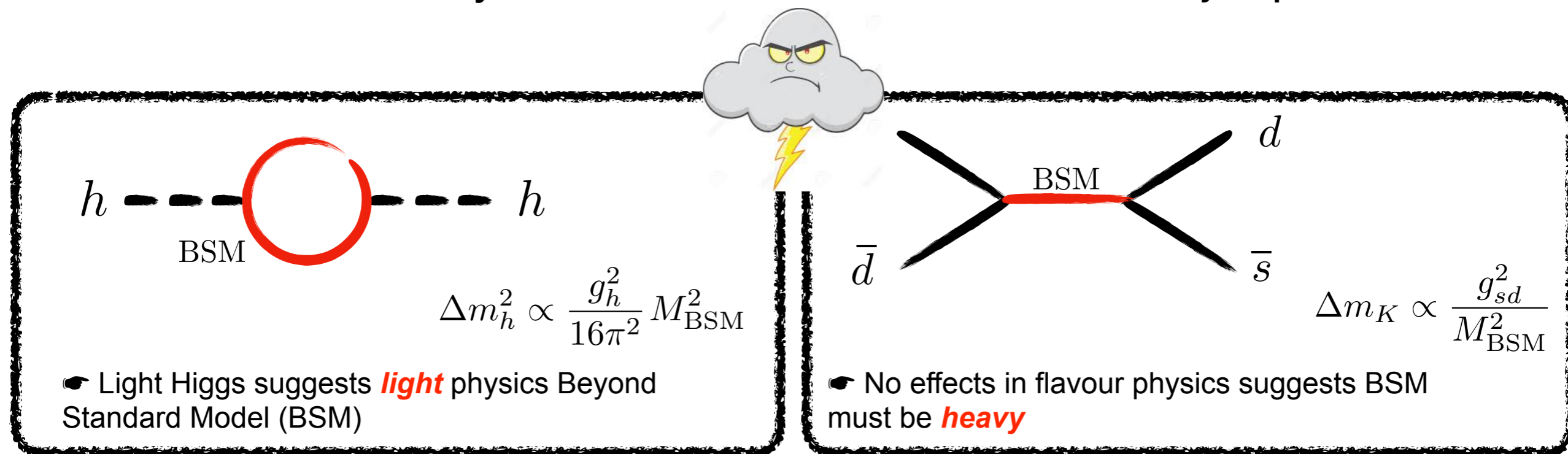

- With this in mind, exploring the energy frontier is our **best opportunity to understand Nature from first principles**
- At the same time, **exploring the Standard Model as a fundamental theory** in its own right is equally compelling

Collider events: the real world

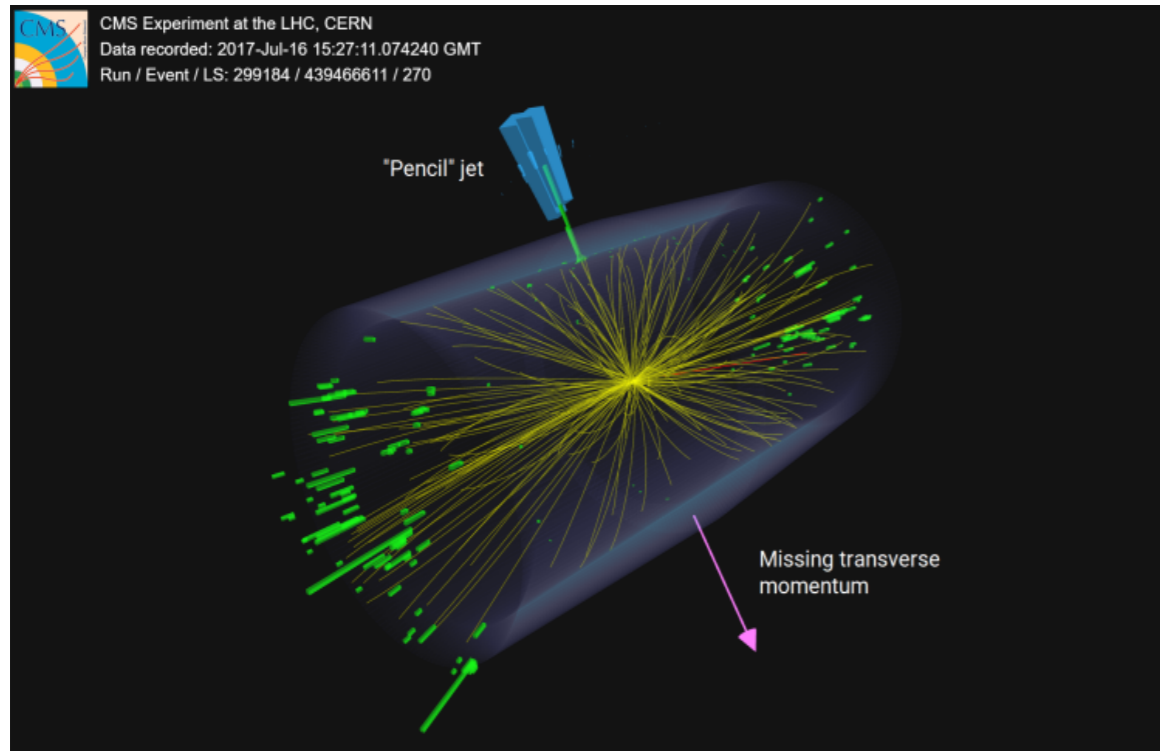

Search for Dark Matter in mono-jet events

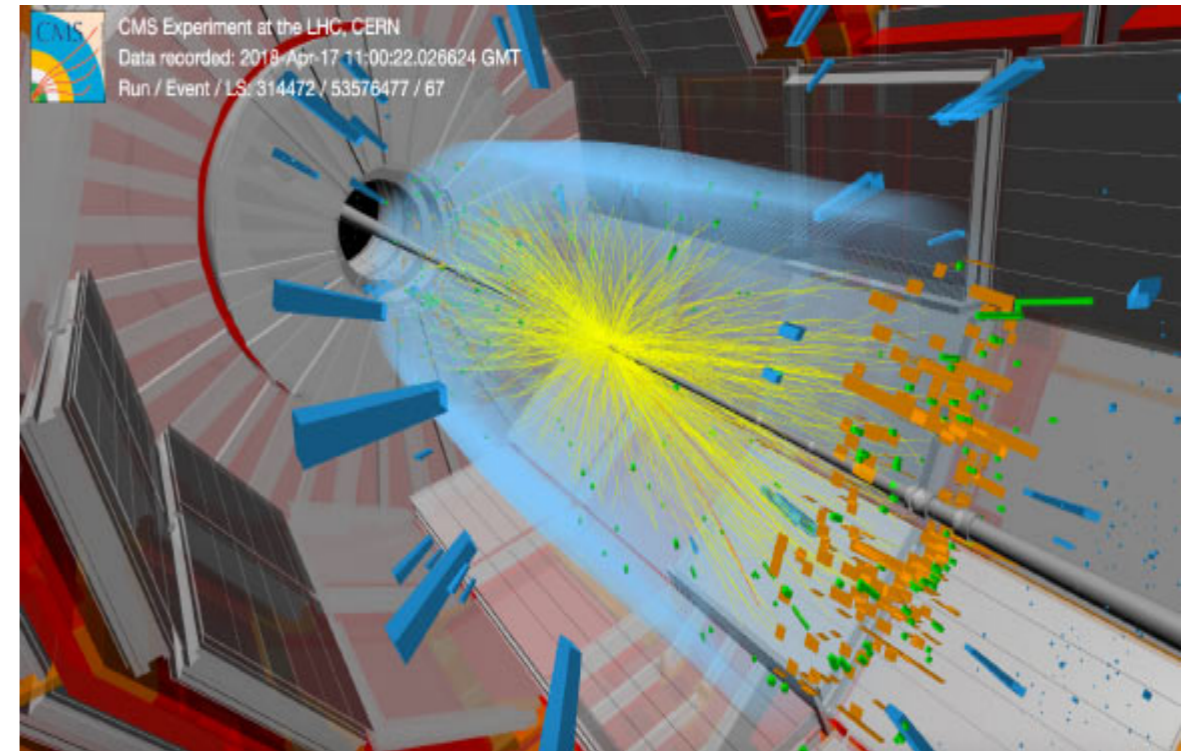

Search for mini-blackholes

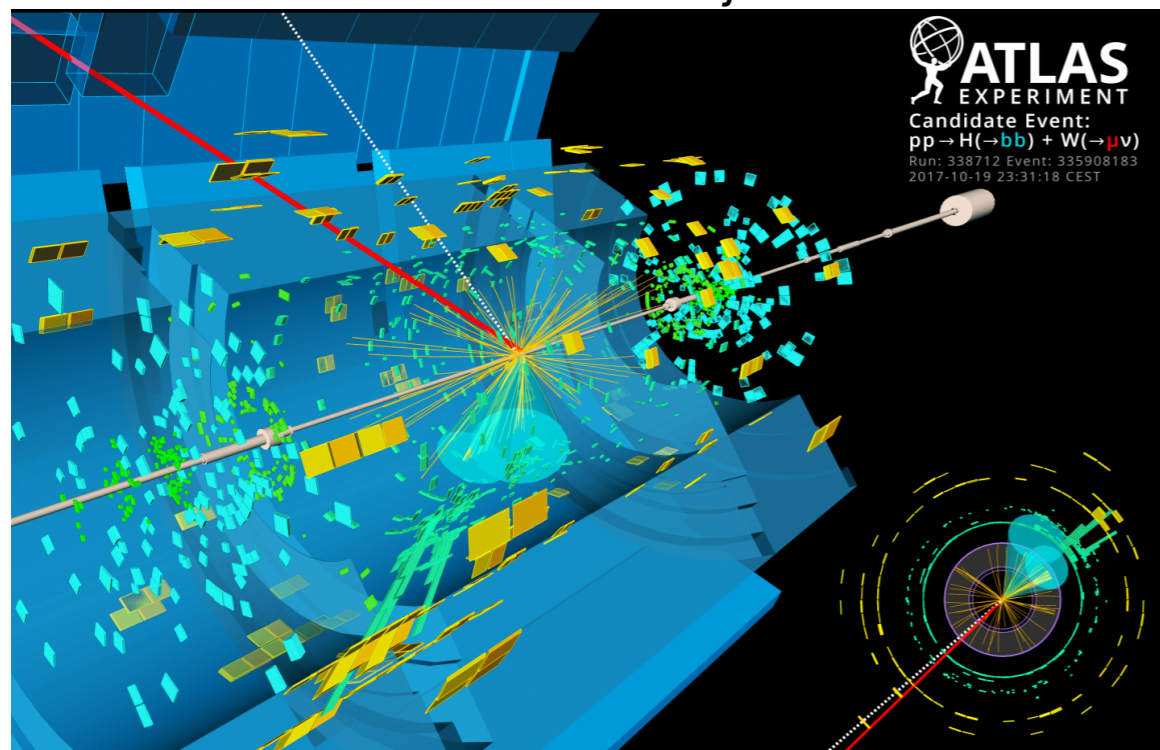

Precision Higgs

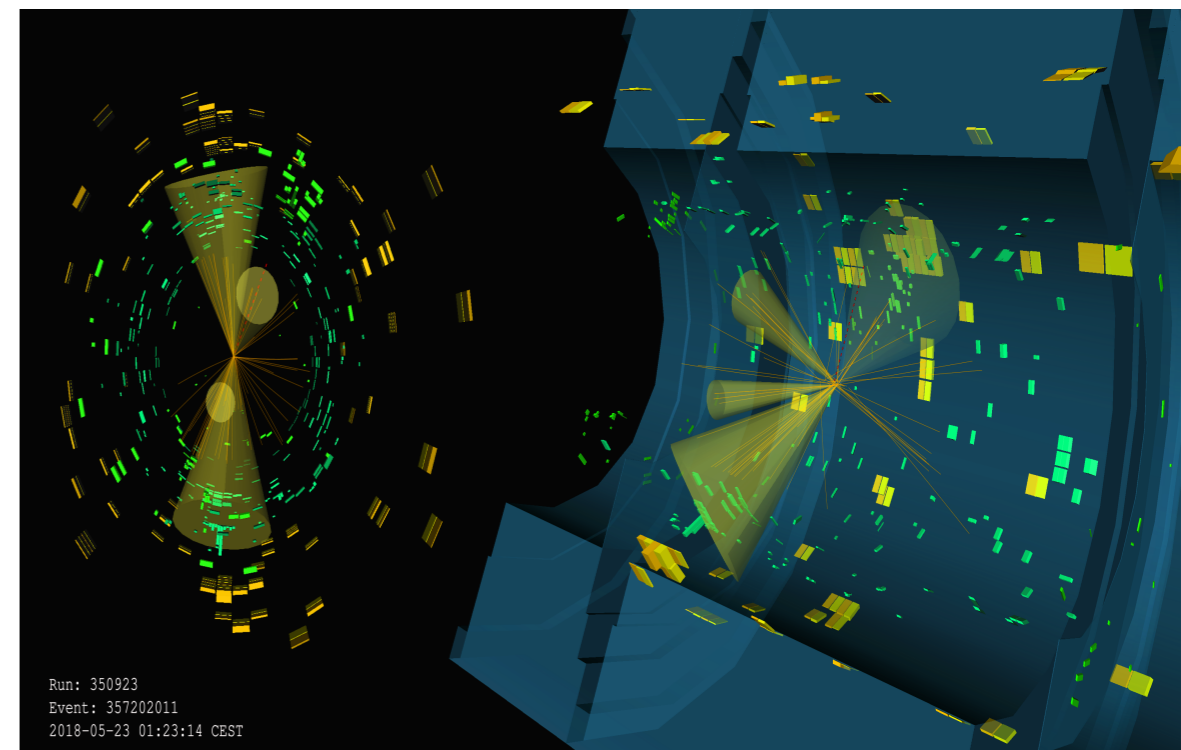

SUSY Searches

Theorist point of view

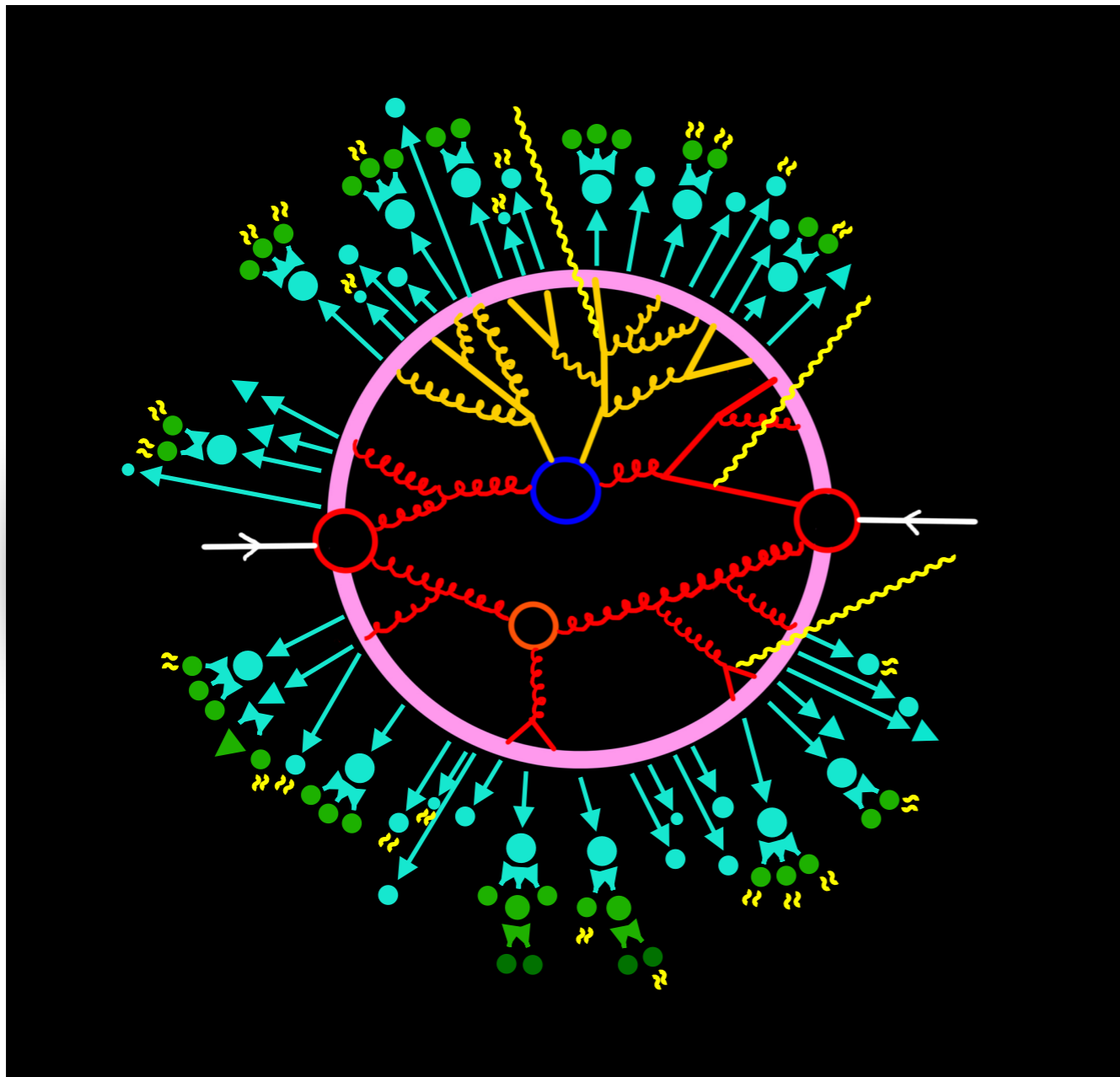

The theory description of collisions involves many elements:

- Hard primary interaction
- Emission of multiple secondary radiation (ISR/FSR)
- Photon radiation
- Formation of hadrons
- Decay of resonances / heavy hadrons
- Possible multi-parton interactions / beam remnants
- Pile-up

Precision description of collider events a multilateral challenge

Role of precision

- test the Standard Model (SM) with highest precision and controlled theory uncertainties
- constrain fundamental parameters and parton distribution functions (PDFs)
- probe New Physics via small deviations from SM predictions
- optimise experimental analyses through design of better observables/selection criteria suitable for precision calculations
- guide future collider designs and priorities

Potential of LHC and future machines, in particular e^+e^- colliders, cannot be exploited without precision theory predictions

Precision a reality

**Z-boson kinematics
to below a percent**

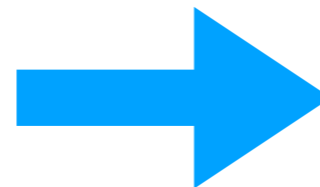
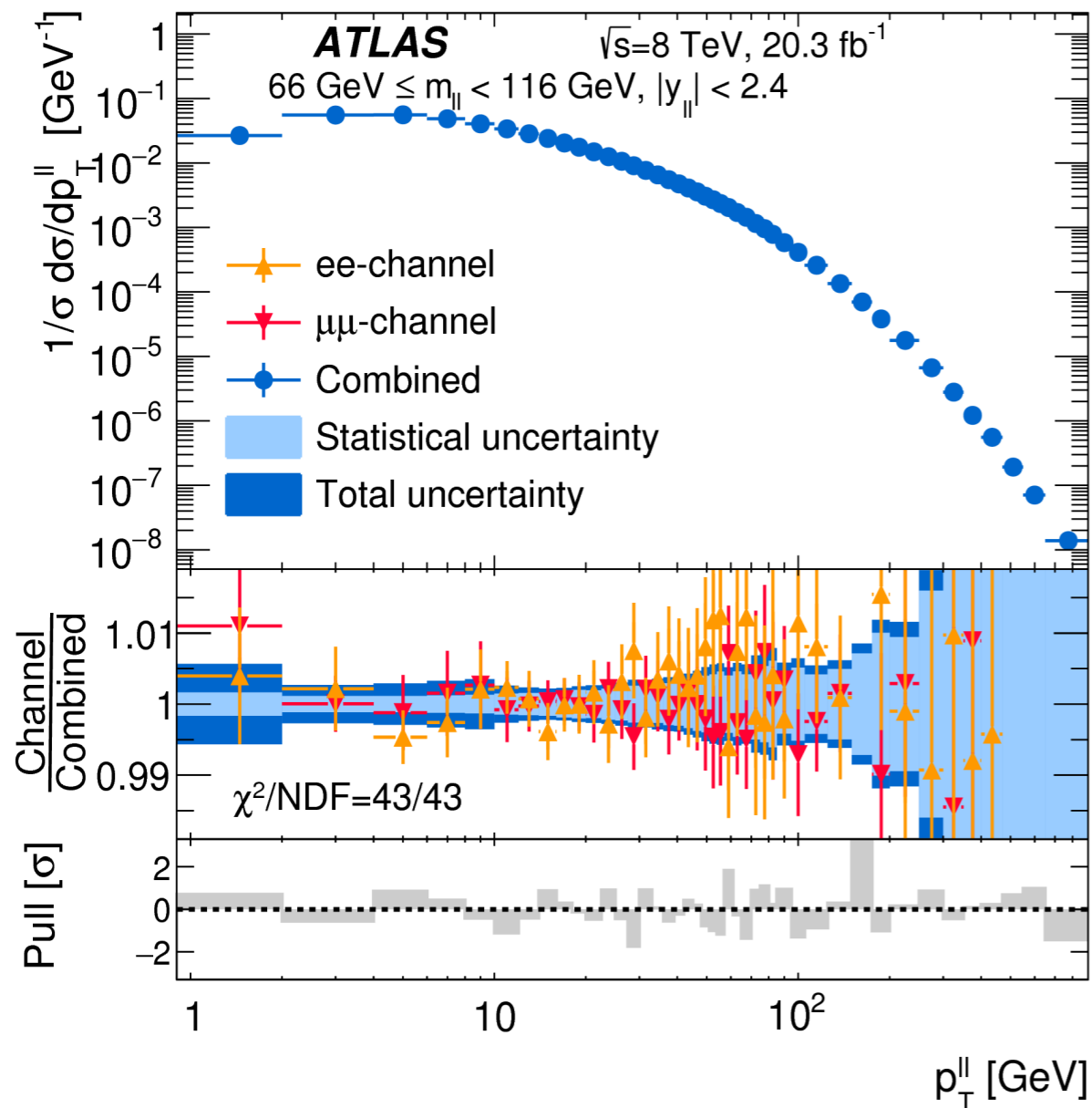

**Z-boson transverse
momentum used recently
to extract strong coupling
with high precision**

$$\alpha_s(m_Z) = 0.11828^{+0.00084}_{-0.00088}$$

ATLAS, 2309.12986

Precision a reality

Z-boson kinematics to below a percent

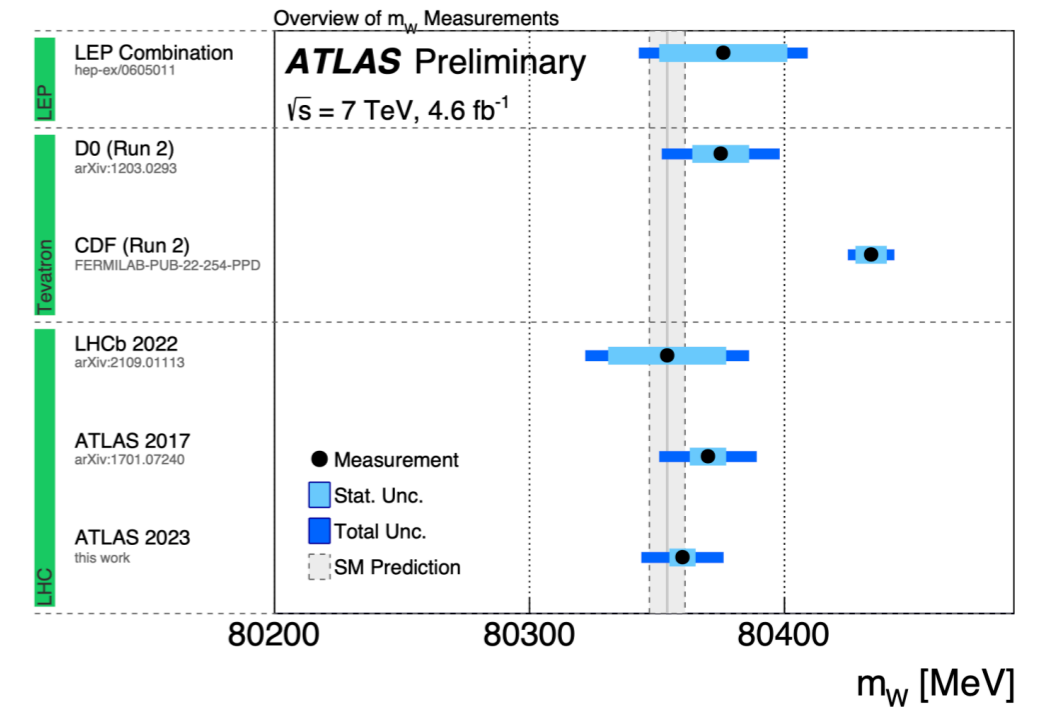
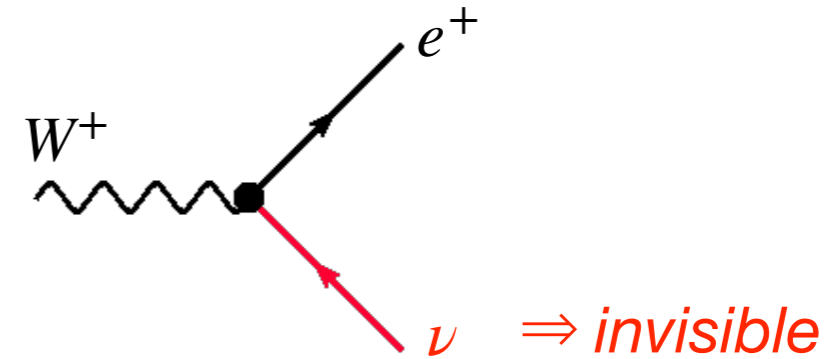
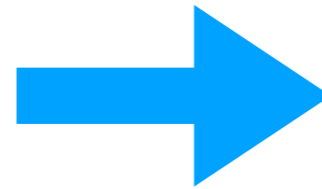
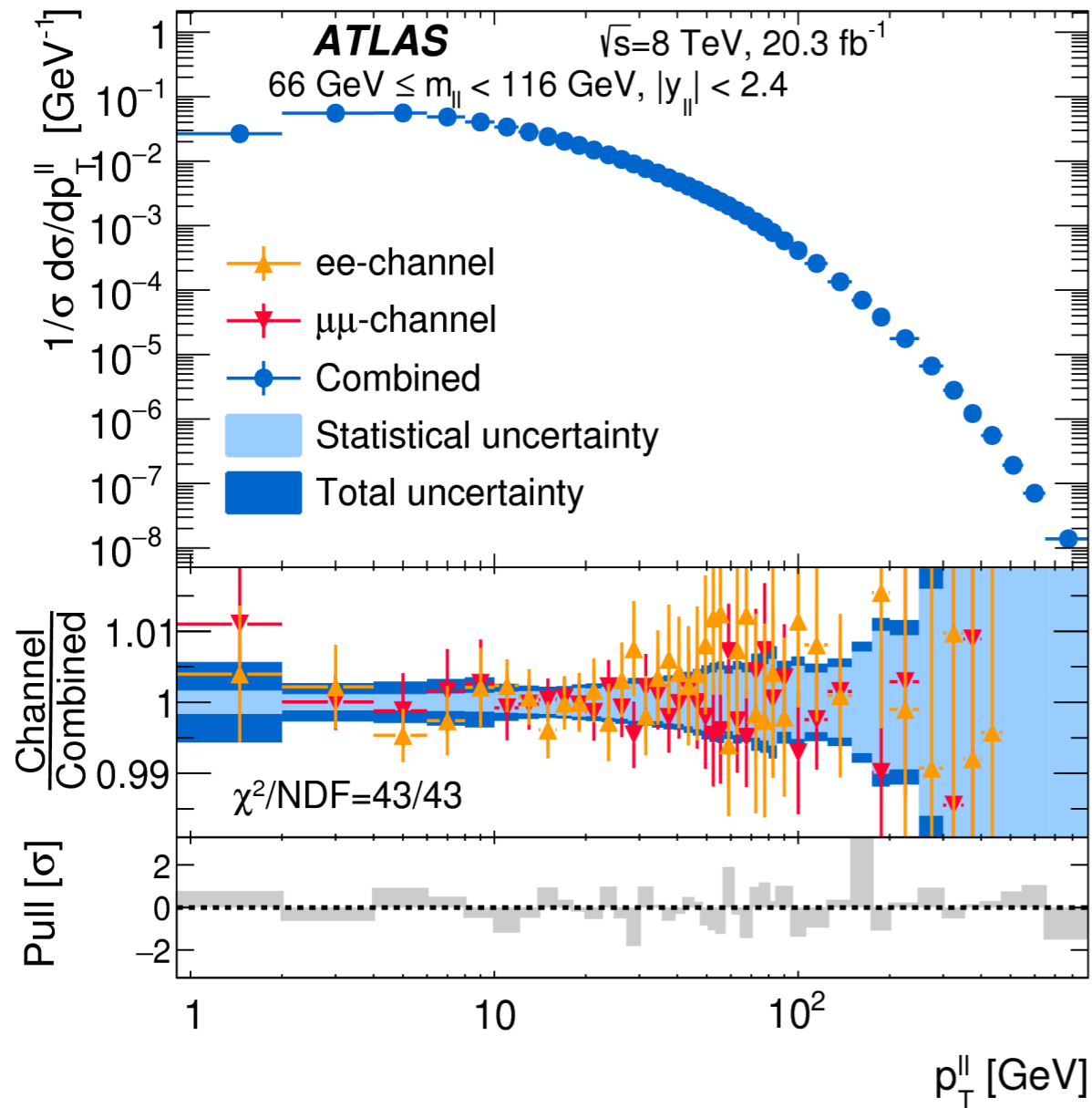

Crucial input for W-boson mass extraction

Hard primary interaction

Electroweak and QCD interactions

The Standard Model: a gauge theory with gauge group

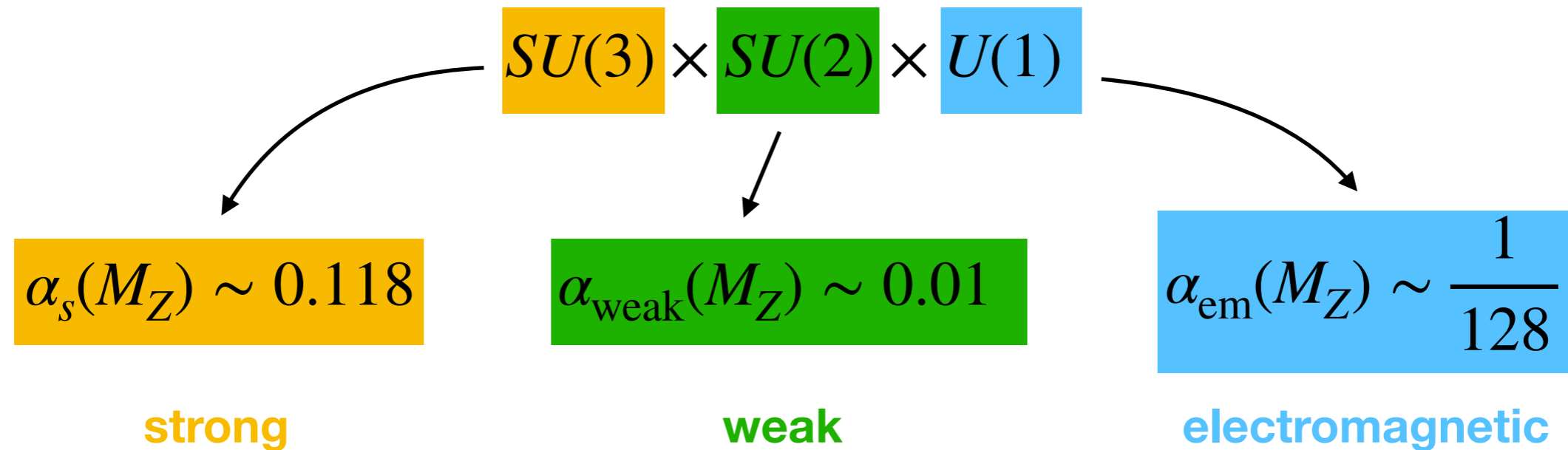

QCD interaction dominate. Rule of thumb: $\alpha_s^2 \sim \alpha_{\text{em}} \sim \alpha_{\text{ew}}$

Interactions at collider energies are *perturbative*, so one can compute cross sections as expansions in the couplings:

$$\sigma = \underbrace{\sigma_0}_{LO} + \underbrace{\alpha \sigma_1}_{NLO} + \underbrace{\alpha^2 \sigma_2}_{NNLO} + \dots$$

Precision achieved by computing more perturbative orders

Perturbative expansions

At any order include on extra real emission or virtual fluctuation:

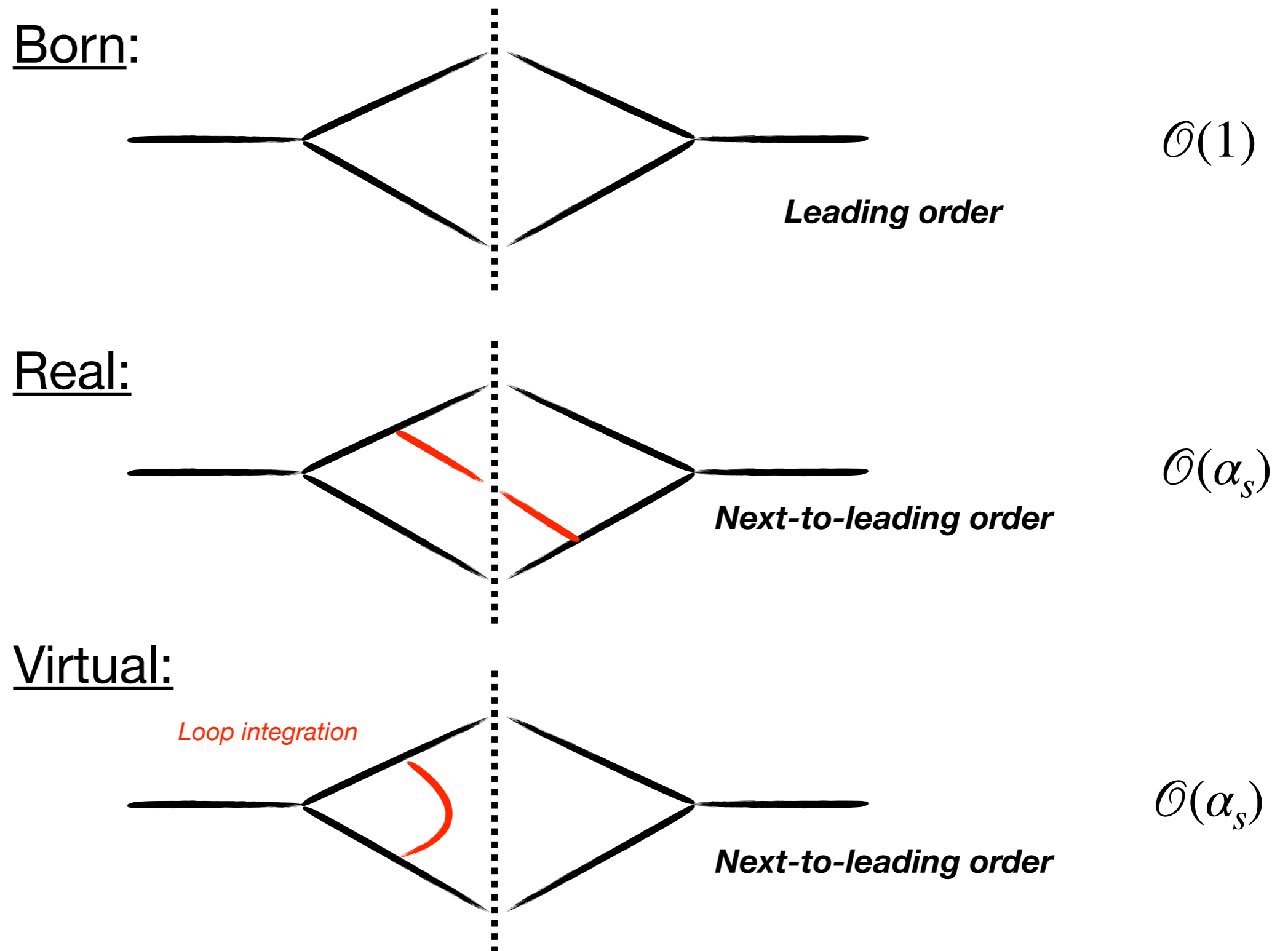

The curse of perturbative expansion

Real and virtual separately divergent, only the sum is physical:

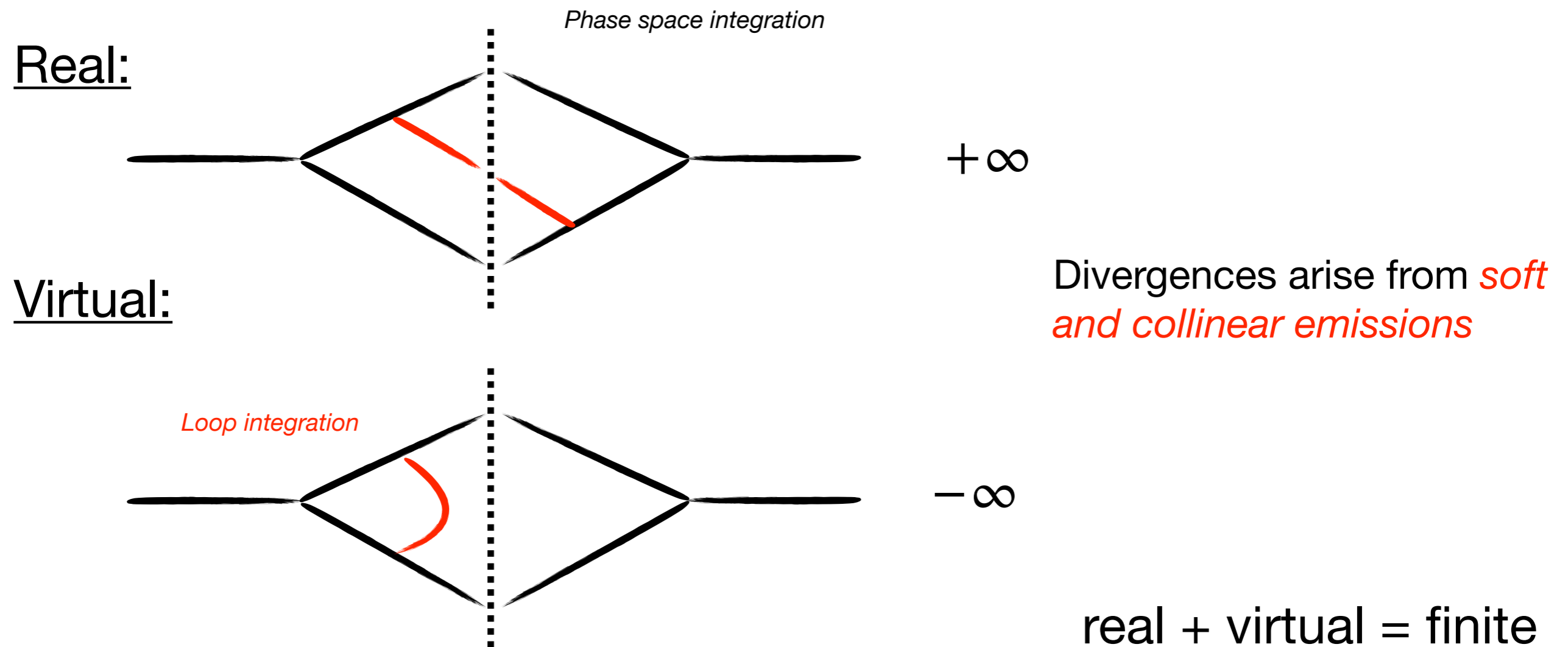

Because of unitarity, the real and virtual contributions are the same in divergent regions, with opposite sign

NLO: one-loop amplitudes

Main one-loop amplitude providers:

- ▶ **BlackHat**(<https://blackhat.hepforge.org/>)
 - ▶ **Collier** (<https://collier.hepforge.org>)
 - ▶ **GoSam** (<https://gosam.hepforge.org>)
 - ▶ **Golem95** (<https://golem.hepforge.org/>)
 - ▶ **Helac-NLO/Helac-1Loop** (<https://helac-phegas.web.cern.ch>)
 - ▶ **Ninja** (<https://ninja.hepforge.org/>)
 - ▶ **Njet** (<https://www.physik.hu-berlin.de/de/pep/tools/njet>)
 - ▶ **NLOX** (<http://www.hep.fsu.edu/~nlox/>)
 - ▶ **OpenLoops** (<https://openloops.hepforge.org>)
 - ▶ **Recola/Recola2** (<https://recola.hepforge.org>)
- ✓ Fast, automated generation and numerical evaluation of one-loop amplitudes
 - ✓ Easy interface with full generators (Sherpa, Herwig, POWHEG, and others)
 - ✓ QCD only, or full SM (QCD+EW)

NLO: general purpose tools

1. MadGraph5_aMC@NLO (<https://launchpad.net/mg5amcnlo>)

- Full automation of NLO QCD and EW
- Process generation via FeynRules/UFO. Supports parton showers via aMC@NLO

2. Sherpa+OpenLoops (<https://sherpa.hepforge.org>, <https://openloops.hepforge.org>)

- SHERPA handles phase space, subtraction, matching, and showering
- OpenLoops provides fast NLO matrix elements. Efficient for multi-leg processes

3. Herwig+Matchbox (<https://herwig.hepforge.org>)

- Herwig's Matchbox module enables automated NLO QCD corrections and matching
- Works with external amplitude providers (OpenLoops, MadGraph, etc.)

4. POWHEG-BOX (<http://powhegbox.mib.infn.it>)

- NLO with matching to parton showers (POWHEG method)
- Semi-automated; requires user input for new processes

5. MCFM (<https://mcfm.fnal.gov>)

- Parton-level code for NLO calculations (less automated)
- Mostly SM processes. Mostly based on analytic calculations, very stable and fast

...

NLO automation

NLO QCD calculations are now fully automated, thanks to:

- ✓ the ability to reduce one-loop amplitudes to master integrals
- ✓ analytic knowledge of all relevant master integrals
- ✓ a systematic understanding of how to handle intermediate divergences (e.g. subtraction/slicing methods)
- ✓ the availability of tools for computing tree-level real radiation

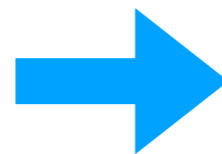

Open challenges at NLO

- numerical stability and efficiency for high multiplicity processes
- NLO corrections to loop-induced processes
- NLO to BSM / EFTs

NNLO: status

2 → 1

2 → 2

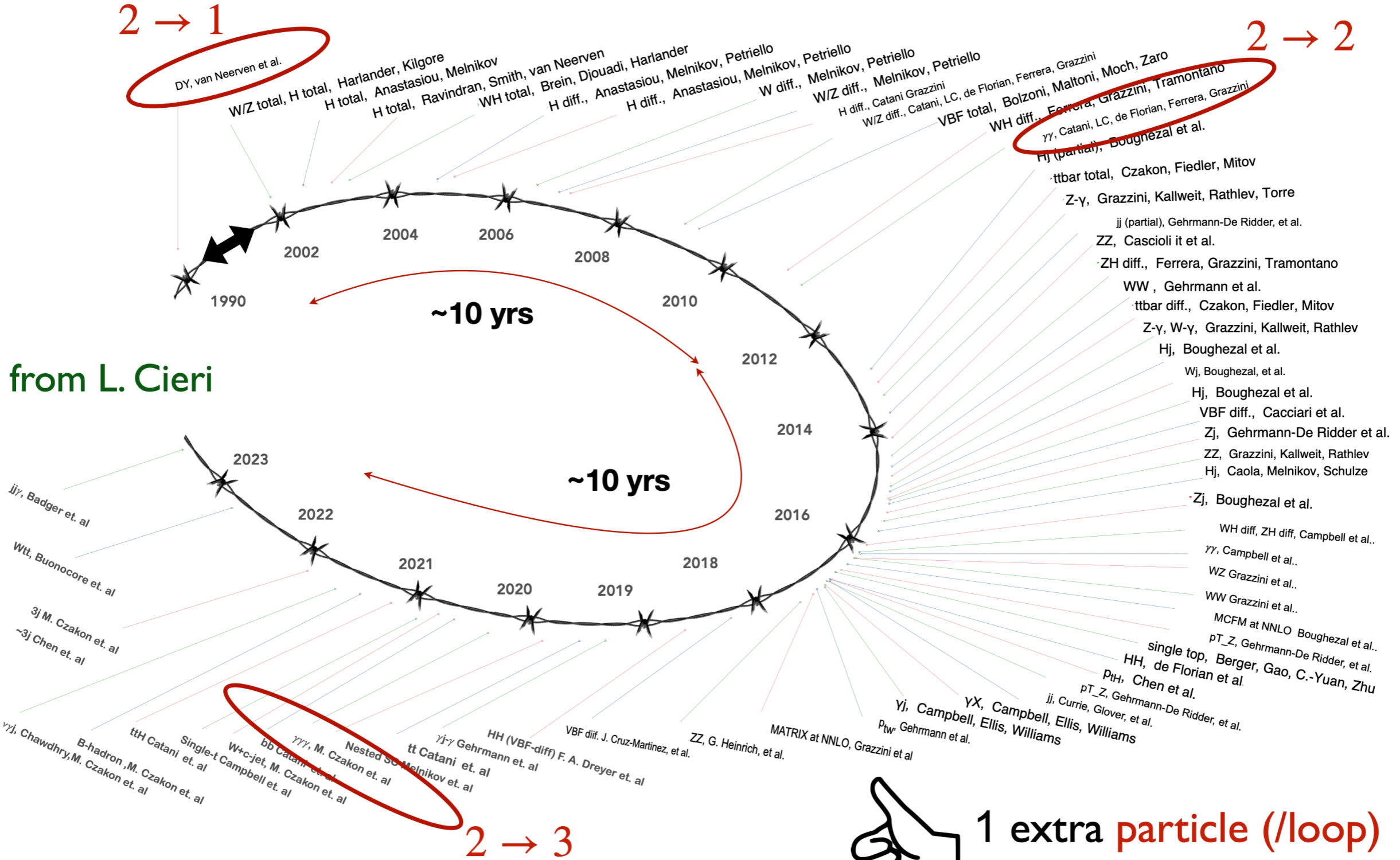

from L. Cieri

⇒ no full automation yet



1 extra particle (/loop) every 10 years

NNLO: ingredients

Amplitudes required at NNLO:

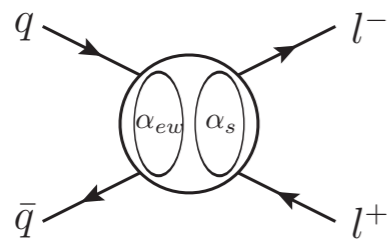

1. two-loop virtual + one-loop squared

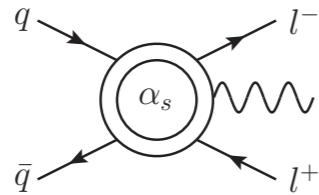
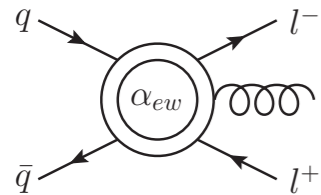
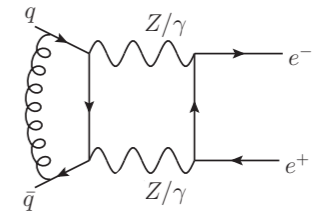

2. one-loop with one extra radiation

[issue: numerical stability in unresolved regions]

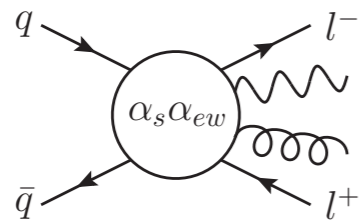
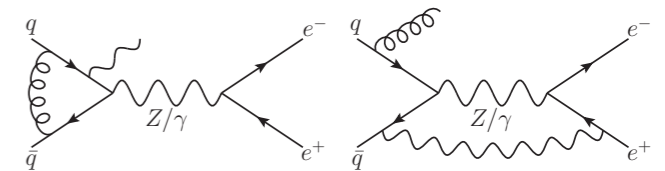

3. Tree-level double real

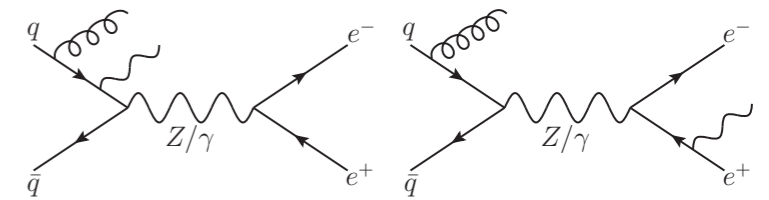

diagrams from C. Signorile-Signorile

NNLO: ingredients

Amplitudes required at NNLO:

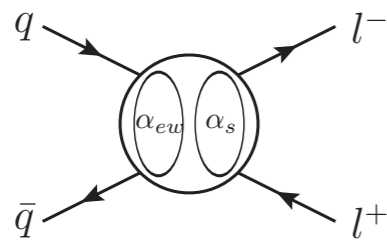

1. two-loop virtual + one-loop squared

The hardest challenge X

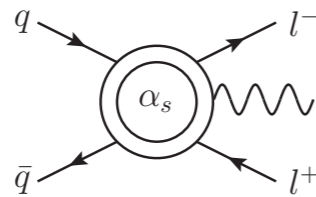
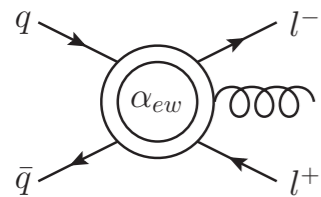
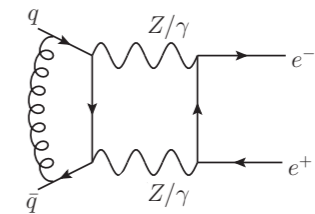

2. one-loop with one extra radiation

[issue: numerical stability in unresolved regions] ✓

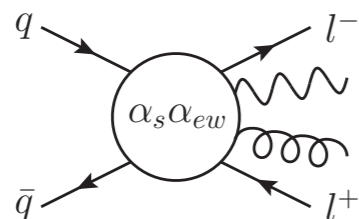
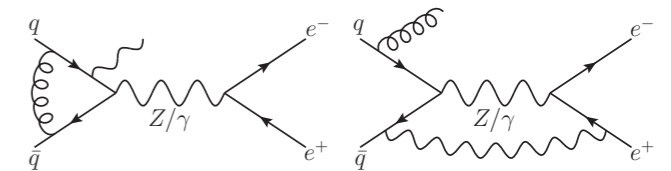

3. Tree-level double real

✓

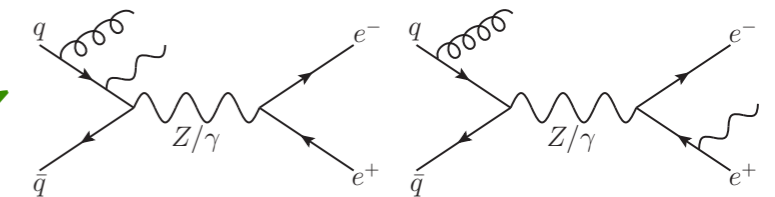

diagrams from C. Signorile-Signorile

2-loop calculations

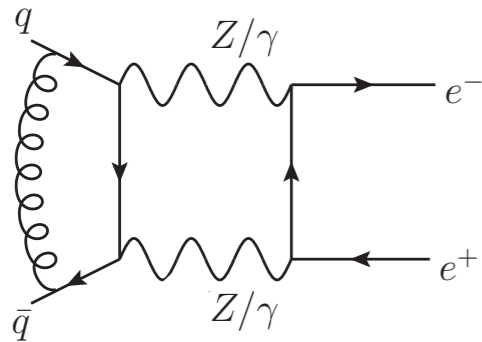

 Feynman
 rules

$$C_{\mu_1 \dots \mu_n \nu_1 \dots \nu_n}(\{p_{\text{ext.}}\}) \int \frac{d^D l_1}{(2\pi)^4} \frac{d^D l_2}{(2\pi)^4} \frac{l_1^{\mu_1} \dots l_1^{\mu_n} l_2^{\nu_1} \dots l_2^{\nu_n}}{D_1 \dots D_N}$$

$$D_i = q_i^2 - m_i^2$$

- The goal is to express a large number of tensor integrals appearing in Feynman diagrams as linear combinations of a small set of master integrals.
- Well established reduction-techniques, e.g.
 - projection on form factors
 - integration-by-parts (IBP) identities
 - Lorentz invariance identities
 - dimensional shift relations
 - ...

2-loop challenge #1: reduction

While the flowchart is rather straightforward:

- define integral family
- generate IBP identities
- solve Laporta algorithm

The challenges involved are substantial and complex:

- explosion in number of terms and algebraic complexity
- finding minimal, linearly independent topologies not trivial
- finding and exploiting symmetries

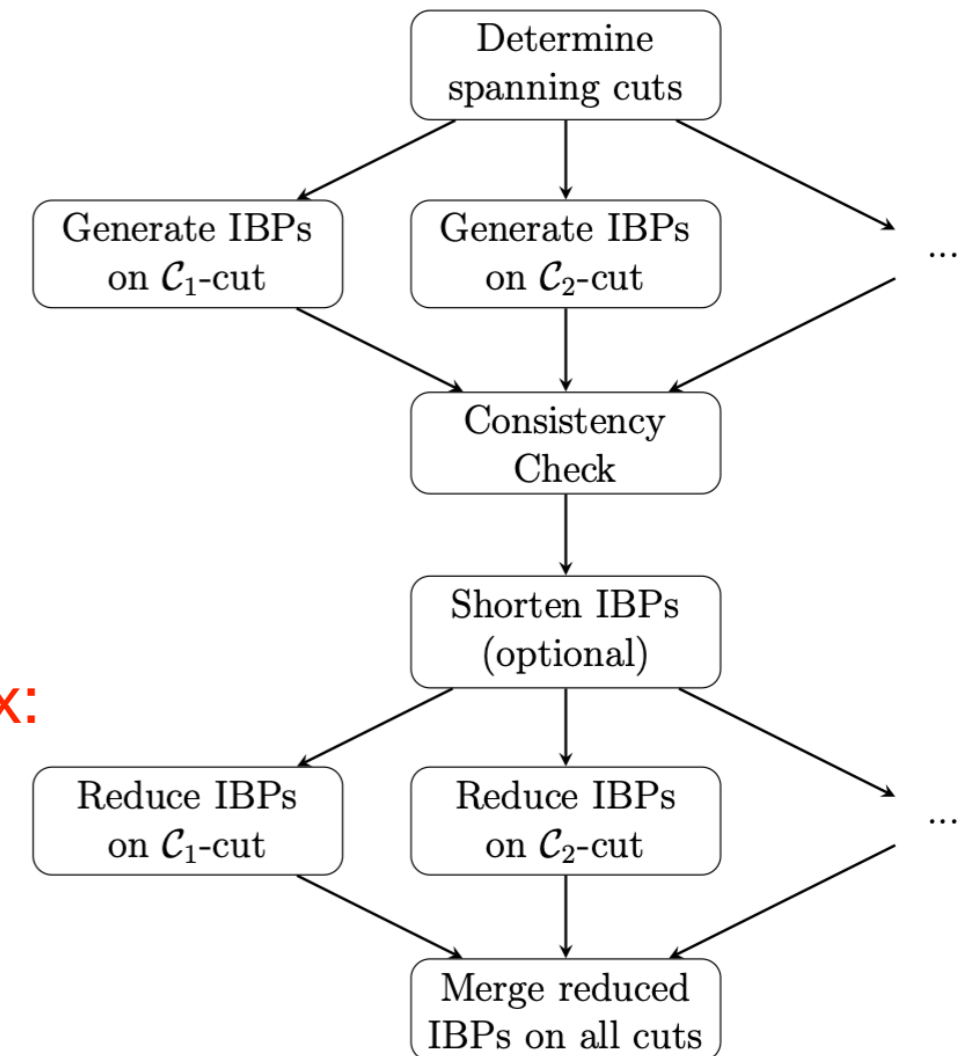

from 2502.20778
[NeatIBP + Kira]

2-loop challenge #1: reduction

Main public tools for IBP reduction of two-loop Integrals:

1. **AIR** (<https://people.phys.ethz.ch/~pheno/air/>)
 - Automates IBP reduction for scalar and tensor integrals to master integrals.
2. **BLADE** (<https://gitee.com/multiloop-pku/blade>)
 - Fast IBP reduction in block triangular form
2. **FiniteFlow** (<https://github.com/peraro/finiteflow-mathtools/>)
 - multivariate functional reconstruction using finite fields and dataflow graphs.
3. **Fire** (<https://gitlab.com/feynmanintegrals/fire>)
 - Uses the Laporta algorithm for efficient IBP reduction of multi-loop integrals.
4. **Kira** (<https://gitlab.com/kira-pyred/kira>)
 - High-performance tool for IBP reduction, particularly for multi-loop integrals.
5. **LiteRed** (<https://github.com/rnlq/LiteRed2>)
 - A C++ program for IBP reduction, optimized for speed and simplicity.
6. **NeatIBP** (<https://github.com/yzhphy/NeatIBP>)
 - small-size integration-by-parts relations for Feynman integrals.
7. **Reduze** (<https://reduze.hepforge.org/>)
 - Automates IBP reduction for scalar and tensor integrals, support both one- and two-loop level.

2-loop challenge #1: reduction

Main public tools for IBP reduction of two-loop Integrals:

1. **AIR** (<https://people.phys.ethz.ch/~pheno/air/>)
 - Automates IBP reduction for scalar and tensor integrals to master integrals.
2. **BLADE** (<https://gitee.com/multiloop-pku/blade>)
 - Fast IBP reduction in block triangular form

Steady progress allows reduction of increasingly complicated processes

4. **NIRA** (<https://github.com/NIRA-py/NIRA>)
 - High-performance tool for IBP reduction, particularly for multi-loop integrals.
5. **LiteRed** (<https://github.com/rnlq/LiteRed2>)
 - A C++ program for IBP reduction, optimized for speed and simplicity.
6. **NeatIBP** (<https://github.com/yzhphy/NeatIBP>)
 - small-size integration-by-parts relations for Feynman integrals.
7. **Reduze** (<https://reduze.hepforge.org/>)
 - Automates IBP reduction for scalar and tensor integrals, support both one- and two-loop level.

2-loop challenge #2: masters

At NLO: the full set of master integral for any process is fully known analytically

At NNLO: the complete set of master integrals is not known. Often non-trivial to verify linear independence

Techniques for evaluation of master integrals:

- ▶ difference and differential equations (DE), including auxiliary mass method
- ▶ Mellin–Barnes representations
- ▶ sector decomposition
- ▶ expansion in limits
- ▶ iterated integrals
- ▶ ...

⇒ ongoing development of several **new analytic and numerical methods**

2-loop challenge #2: masters

Most used public codes:

1. pySecDec (<https://github.com/gudrunhe/secdeco>)

- Numerical evaluation of master integrals using sector decomposition

2. FIESTA (<https://gitlab.com/feynmanintegrals/fiesta>)

- Numerical evaluation of master integrals using sector decomposition

3. AMFLOW (<https://gitlab.com/multiloop-pku/amflow>)

- Numerical evolution of master integrals using finite flow method

- ▶ powerful checks of analytic calculations
- ▶ used directly in numerical/phenomenological implementations
- ▶ if the evaluation is very slow, used to construct integration grids to be just interpolated on-the-fly

2-loop challenge #2: masters

Open challenges:

- Elliptic and beyond:
Master integrals with elliptic or more general functions (e.g. modular forms) are not expressible in terms of multiple polylogarithms; the theory of these functions is still being developed.
- Numerical evaluation stability:
Some integrals can only be evaluated numerically, but the precision and speed required for collider applications are often challenging/prohibitive.
- Automation bottlenecks:
While IBP and DE methods are largely automated, choosing good bases and simplifying expressions still requires expert intervention.

Frontier: 2 to 2 process with full off-shell legs, 2-loop integrals with 3-4 scales, multi-leg QCD-EW mixed contributions ...

NNLO challenge #3: singularities

While full results are finite, double-virtual, real-virtual and double-real amplitudes involve *intermediate singularities*. Since they live in different phase-spaces (Φ_n , Φ_{n+1} , and Φ_{n+2}) the cancellation of singularities must occur *before numerical evaluation*.

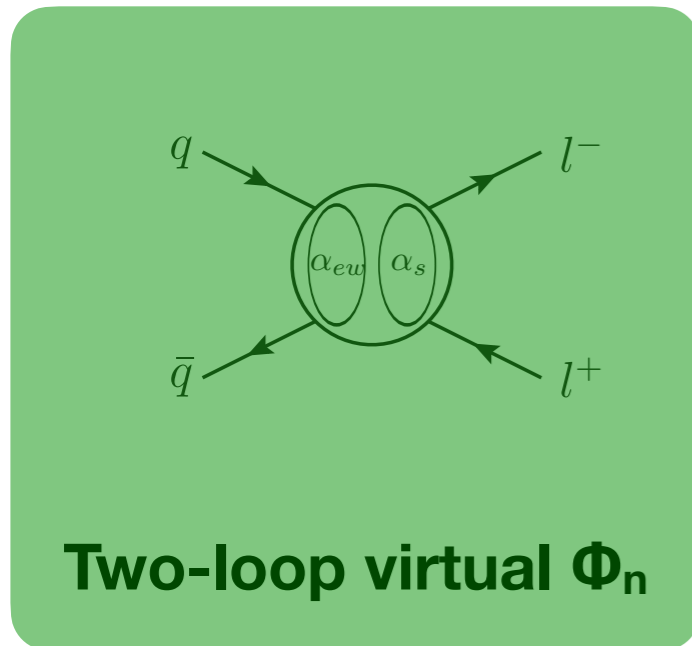

$\pm \infty$

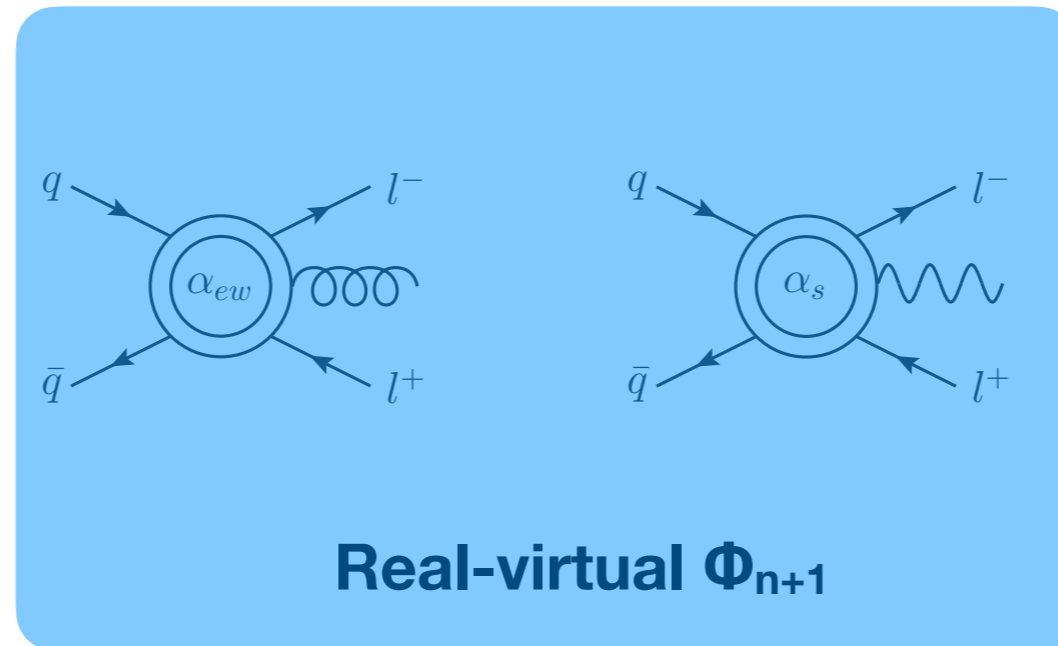

$\pm \infty$

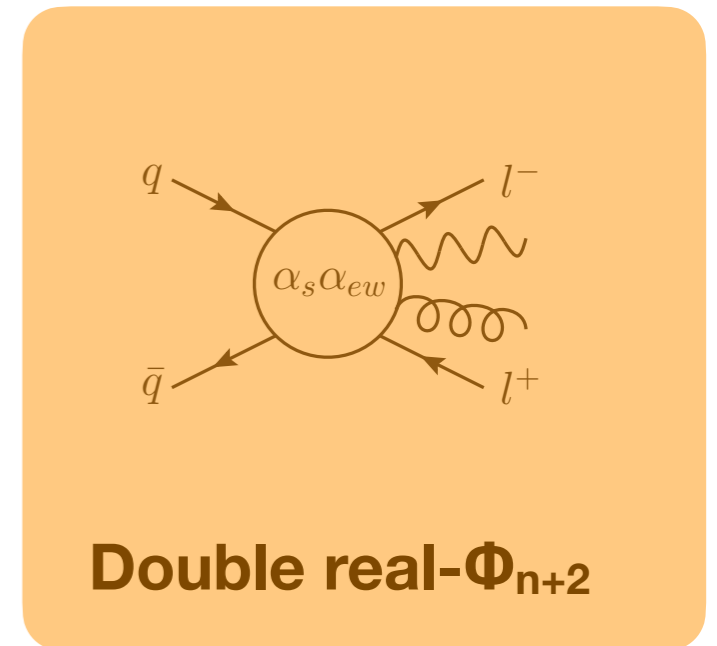

$+\infty$

NNLO challenge #3: singularities

Two core ideas

Slicing

$$\sigma(X) = \int_0^{\tau_{\text{cut}}} \frac{d\sigma_{\text{approx}}(X)}{d\tau} + \int_{\tau_{\text{cut}}} \frac{d\sigma(X)}{d\tau}$$

finite \Rightarrow numerical evaluation

approximate evaluation close to soft-collinear limits

- Non-local in the phase space
- Dependence on the slicing parameter

Subtraction

$$\int d\Phi_D |\mathcal{M}|^2 F_J = \int d\Phi_4 (|\mathcal{M}|^2 F_J - K) + \int d\Phi_D K$$

finite \Rightarrow numerical evaluation

soft-collinear counterterms \Rightarrow poles in $1/\epsilon$

- Local in the phase space
- Construction and integration of counterterms hard/process specific

Many practical realisations of these ideas at two-loops and beyond

NNLO challenge #3: singularities

Method	Local?	Analytic?	Examples	Public tool
Antenna subtraction [Gehrmann-De Ridder et al. '05]	✓	✓	$e^+e^- \rightarrow 3$ jets, DIS, Z/H+jet, dijets, diphoton, VBF Higgs ...	NNLOJet
q_T subtraction [Catani, Grazzini '07]	✗	✓	Colour singlet processes (2 to 2) , tt, bb, ttH, ttW	HNNLO, DYNNLO, MCFM
N-jettiness subtraction [Boughezal et al. '15; Gaunt et al. '15]	✗	✓	V+jet, H+jet, top decay, single top	Geneva, MCFM
Sector improved residue subtraction [Czakon '10; Czakon, Heymes '14]	✓	✗	tt, Higgs+jet, inclusive jet, W+jet, 3γ , 2γ +jet, γ + 2 jet, 3 jets, B-hadrons	STRIPPER (private)
Local analytic subtraction [Magnea, Maina, Pelliccioli, Signorile-S., Torielli, Ucciratali. '18-'20]	✓	✓	$e^+e^- \rightarrow 2$ jets	Private code
Nested soft-collinear subtraction [Caola, Melnikov, Rontsch '17]	✓	✓	VH, VBF QCD-EW Drell Yan	Private code
ColourFull subtraction [Del Duca, Duhr, Somogyi, Trocsanyi '05]	✓	✓	$e^+e^- \rightarrow 3$ jets, $H \rightarrow bb$, H	NNLOCAL
Projection to Born [Cacciari, Dreyer, Karlberg, Salam, GZ '15]	✓	✓	VFB H, DIS, $H \rightarrow bb$, HH, t-channel single top [also jet in DIS, $H \rightarrow bb$, $gg \rightarrow @$ N3LO)	Private codes
Loop Treel duality [Bierenbaum, Catani, Draggiotis, Rodrigo '10, Capatti, Hirschi, Kermanschah, Pelloni, Ruijl '19]	✓	✗	$\gamma^* \rightarrow 2$ jets, $\gamma^* \rightarrow tt$	Private code
Locally finite two-loops [Anastasiosu, Sterman '18]	✓	✗	Multi-photon in e^+e^- , multi-Higgs and EW bosons finite finite top-mass, electroweak production through gluon fusion	Private code

Phenomenological examples

Example: $gg \rightarrow HH$

Bizon et al. 1810.04665

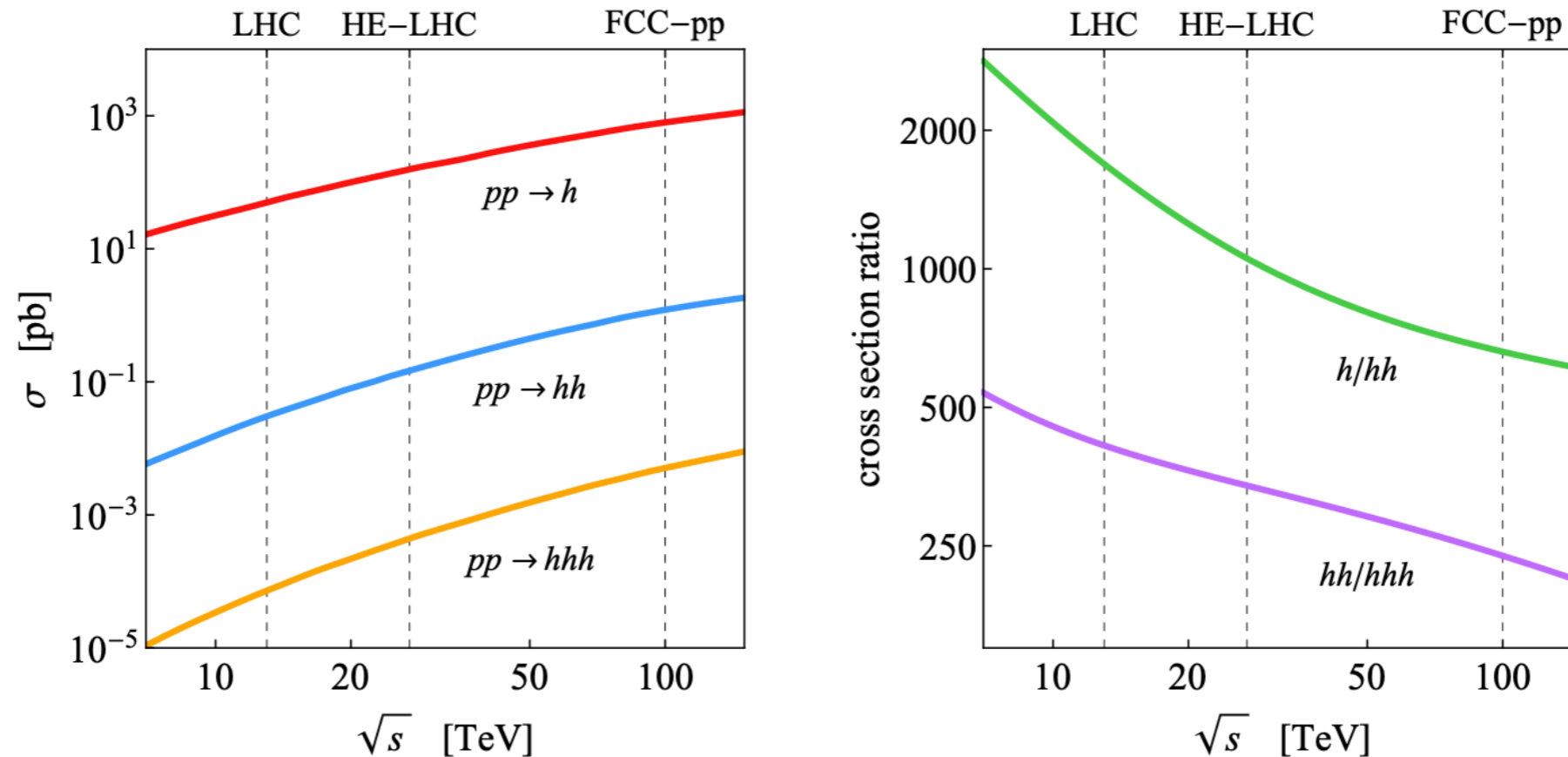

- Double-Higgs production golden channel for the direct measurement of the Higgs self-coupling, the footprint of the SM Higgs boson and of Higgs potential
- Small cross section because of accidental cancellations and phase space effect
- Interesting also in the context of possible new resonances (2HDM, MSSM, RS, ...)

Example: $gg \rightarrow HH$

$$\mathcal{L} = -\frac{1}{4} F_{\mu\nu} F^{\mu\nu} + i \bar{\Psi} \not{D} \Psi + h.c. + \bar{\Psi}_i y_{ij} \Psi_j \phi + h.c. + |D_\mu \phi|^2 - V(\phi)$$

$$V(H) = \lambda v^2 H^2 + \lambda v H^3 + \frac{1}{4} \lambda H^4 - \frac{1}{4} \lambda v^4$$

Electroweak symmetry breaking: $\phi \rightarrow H$

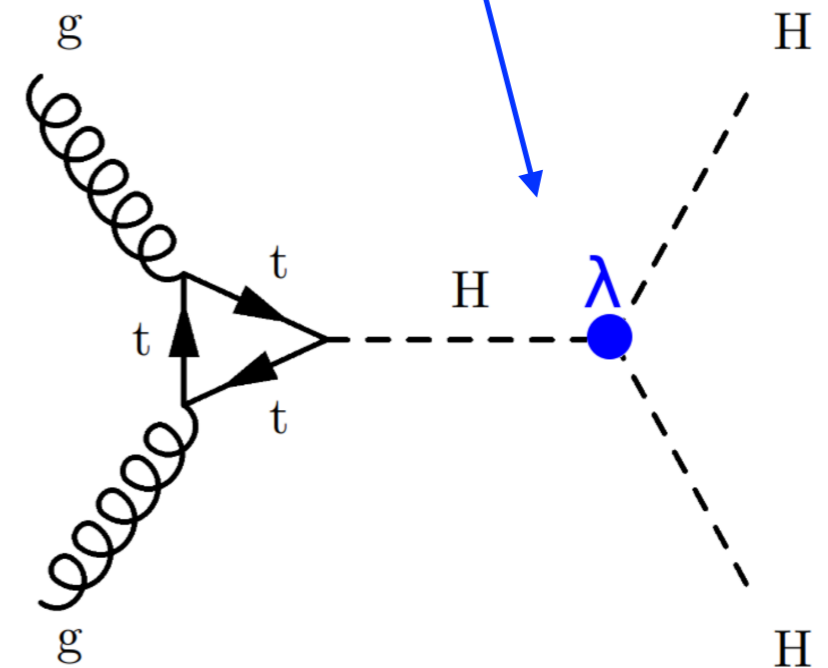

Measuring the HH production rate is our most direct probe of the Higgs potential

Example: $gg \rightarrow HH$

Three search channels dominate sensitivity in HH searches* at the LHC**:

HH \rightarrow 4b: largest rate, but very large backgrounds

The most events, but also the most experimentally challenging

HH final state branching fractions

	bb	WW	$\tau\tau$	ZZ	$\gamma\gamma$
bb	34%				
WW	25%	4.6%			
$\tau\tau$	7.3%	2.7%	0.39%		
ZZ	3.1%	1.1%	0.33%	0.069%	
$\gamma\gamma$	0.26%	0.10%	0.028%	0.012%	0.0005%

HH \rightarrow 2b2 τ : good compromise between rate & bkg.

Good balance between signal purity and event rate

HH \rightarrow 2b2 γ : "golden channel", but very small rate

From S. Cooperstein

Example: $gg \rightarrow HH$

Today's 95% C.L. upper limit on the HH production rate

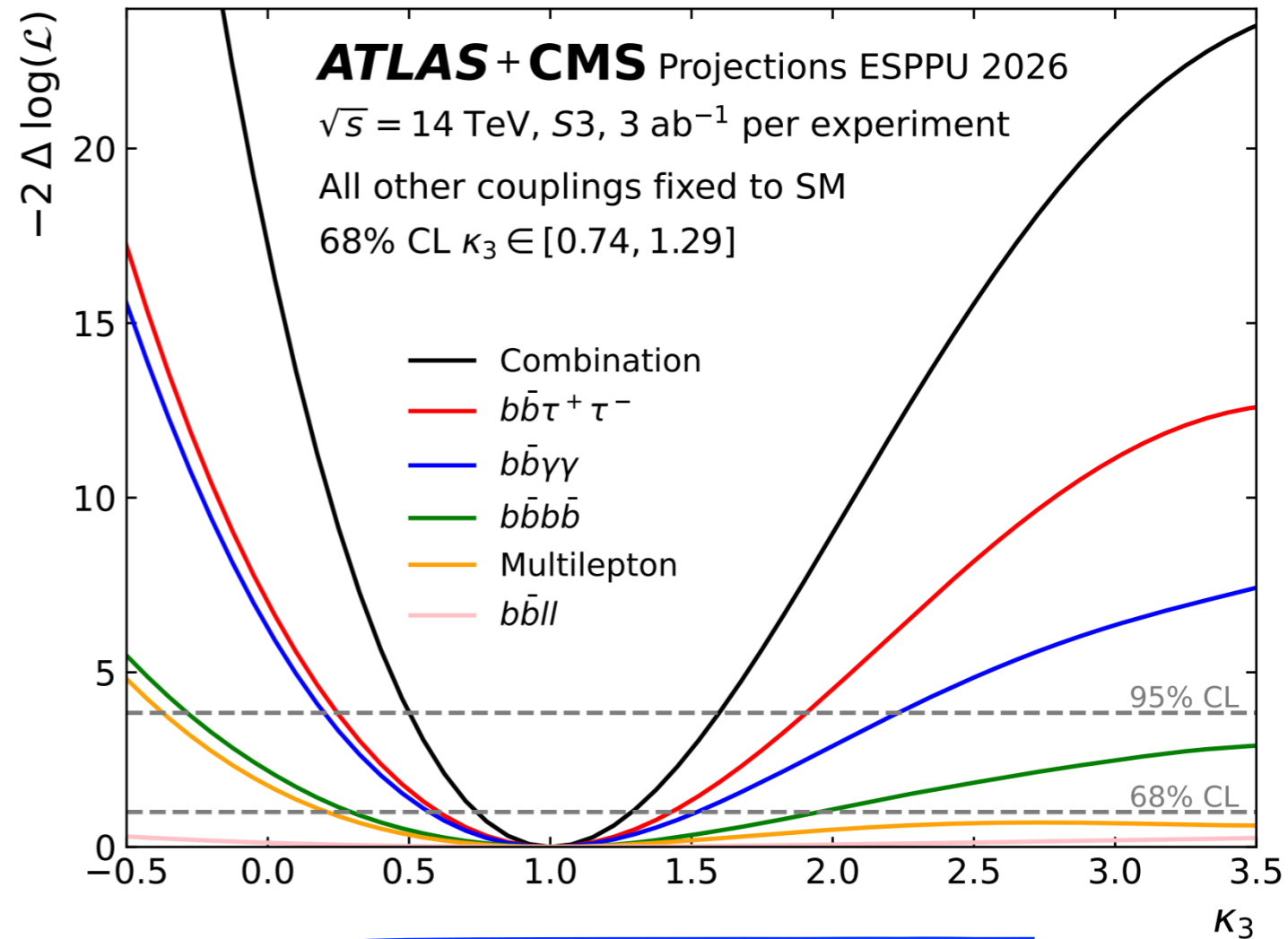
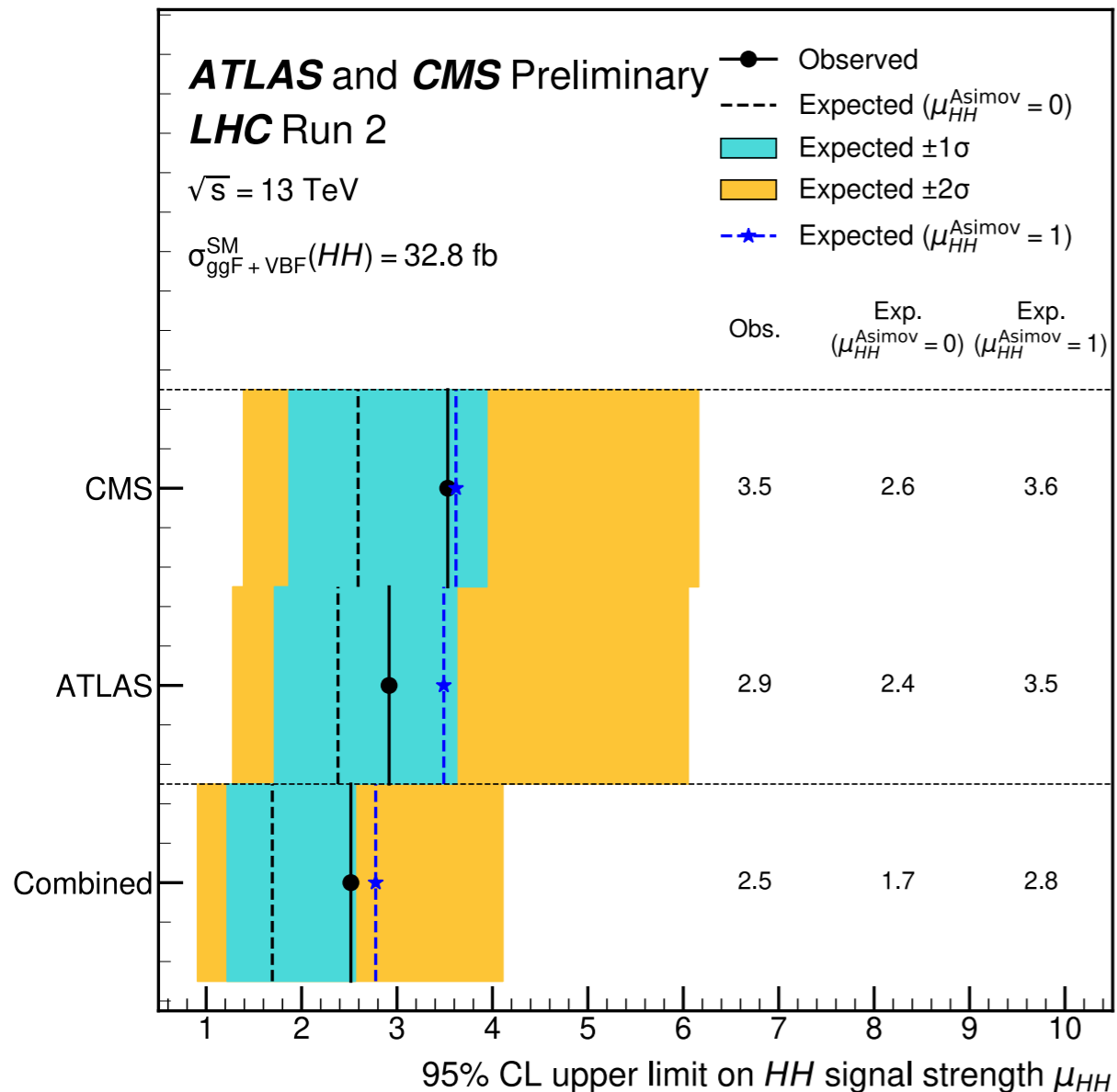

$0.74 < \kappa_\lambda < 1.29$ (68% C.L.)!

After HL-LHC program expect 7σ on HH cross-section and 30% precision on λ

$gg \rightarrow HH: LO$

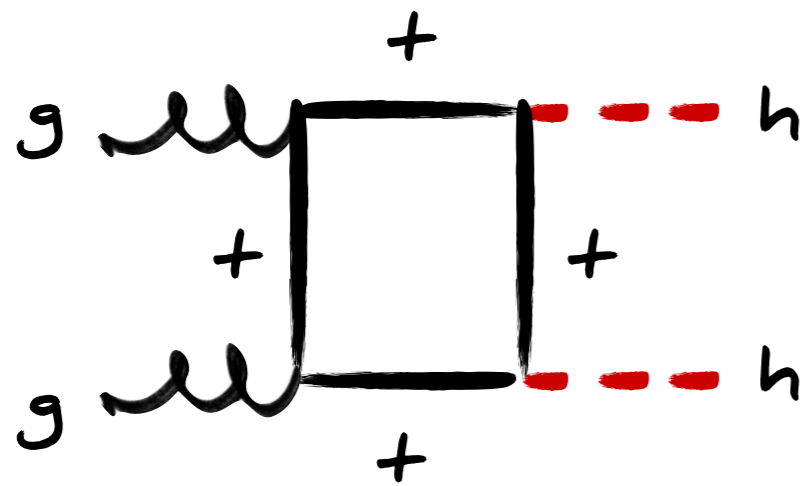

\ominus

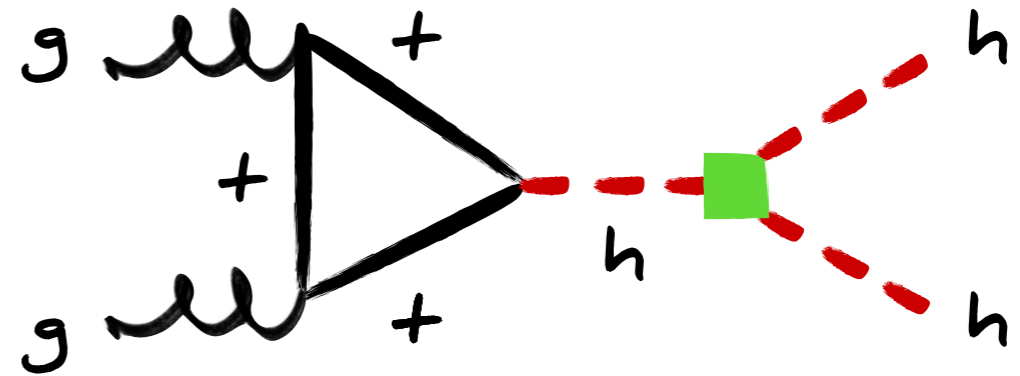

LO amplitude ✓

Eboli, Marques, Novaes, Natale '87
Glover, van der Bij '88

Going beyond LO highly non-trivial

gg → HH: beyond LO

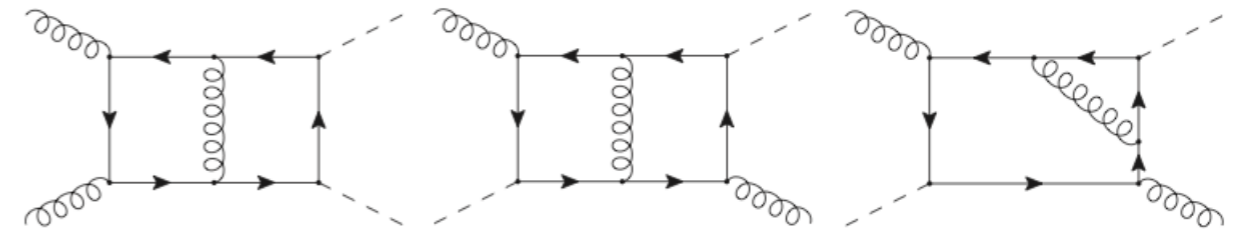
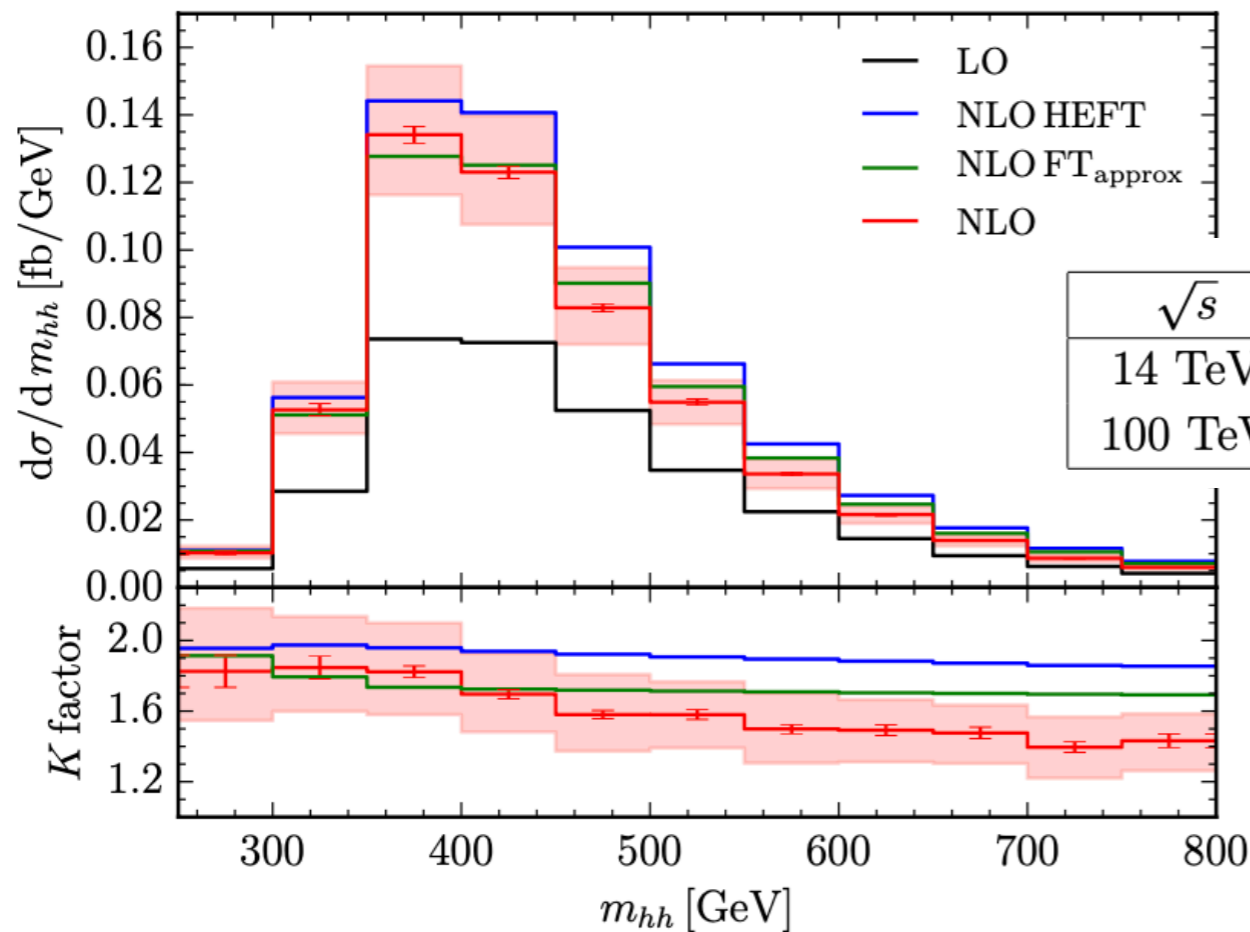

\sqrt{s}	LO	B-i. NLO HEFT	NLO FT _{approx}	NLO
14 TeV	19.85 ^{+27.6%} _{-20.5%}	38.32 ^{+18.1%} _{-14.9%}	34.26 ^{+14.7%} _{-13.2%}	32.91 ^{+13.6%} _{-12.6%}
100 TeV	731.3 ^{+20.9%} _{-15.9%}	1511 ^{+16.0%} _{-13.0%}	1220 ^{+11.9%} _{-10.7%}	1149 ^{+10.8%} _{-10.0%}
		<i>approximate NLO</i>	<i>approximate NLO</i>	<i>exact NLO</i>

Borowka et al. '16

As for single Higgs production very large NLO corrections and large residual uncertainties ⇒ strong motivation to improve precision

gg → HH: approx NNLO

Since a full NNLO (3-loop) is out of reach, clever approximations developed:

- ▶ High energy expansion $s, |t|, \gg m_t^2, m_H^2$
- ▶ Small- t expansion $s, m_t^2, \gg |t|, m_H^2$

Idea is to fully cover the physically relevant phase space with the two approximations (reminiscent, and exploits, the strategy of regions, according to which full results are recovered by summing over all relevant regions at integrand level)

Robust validation using overlap regions, lower orders and numerical results

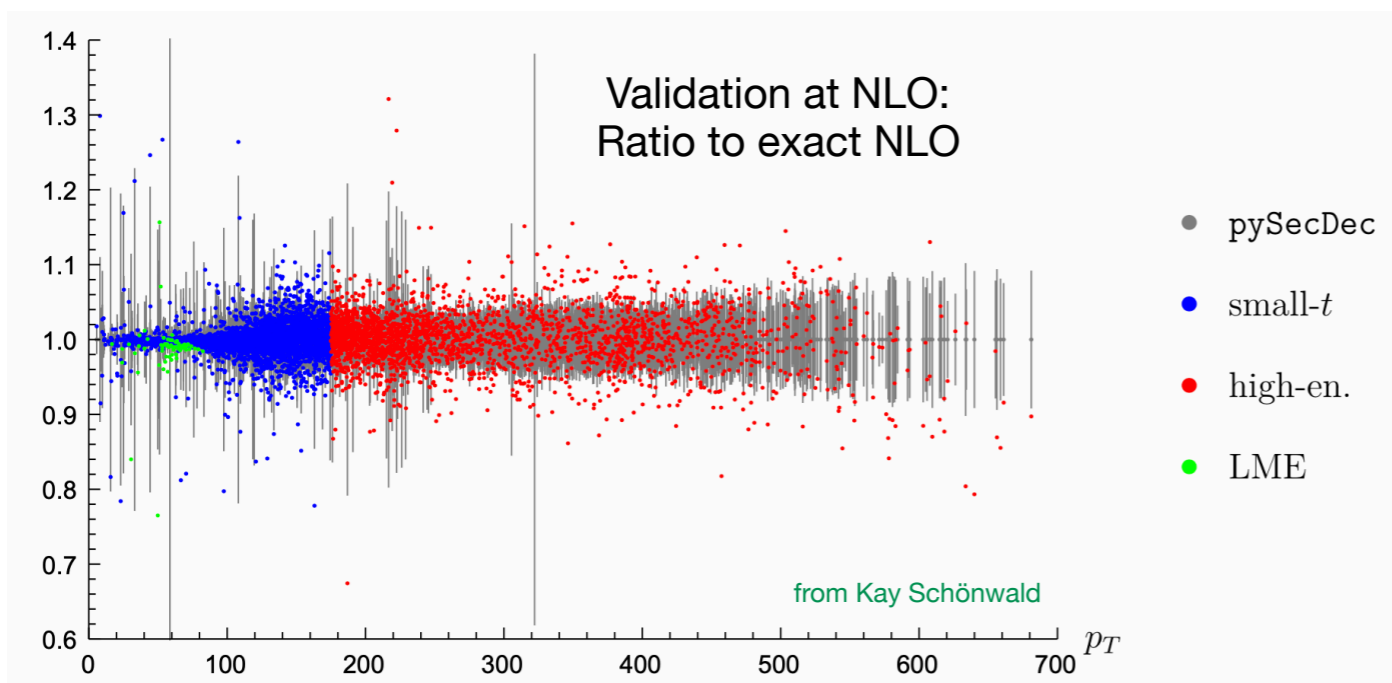

These and similar approximations (soft Higgs, massification, threshold exp., large N_c , ...) are expected to become increasingly relevant as we aim to **halve theoretical uncertainties** — a common target in future projections.

Top-pair production in association with a Higgs boson

Key process to measure directly the top-Yukawa coupling.

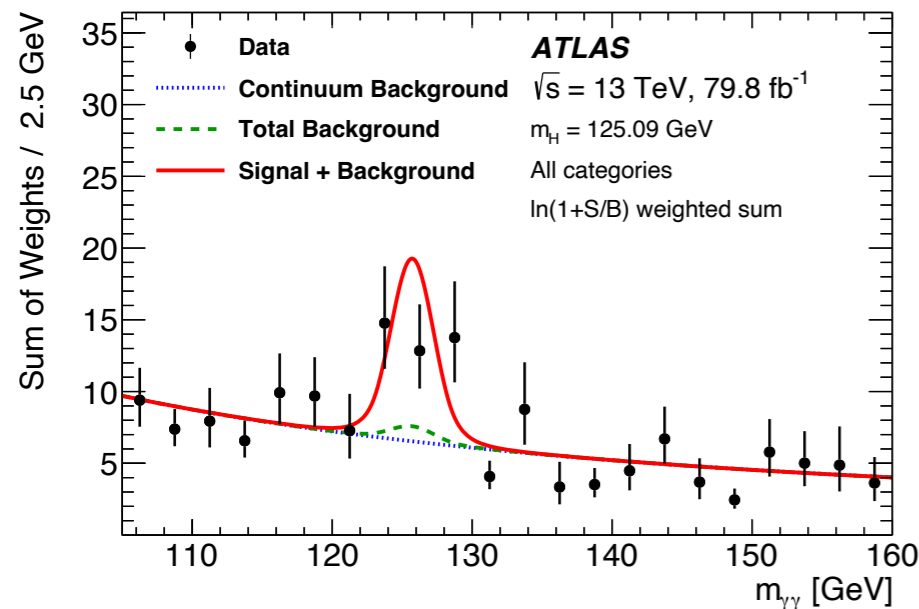

ATLAS 1806.00425

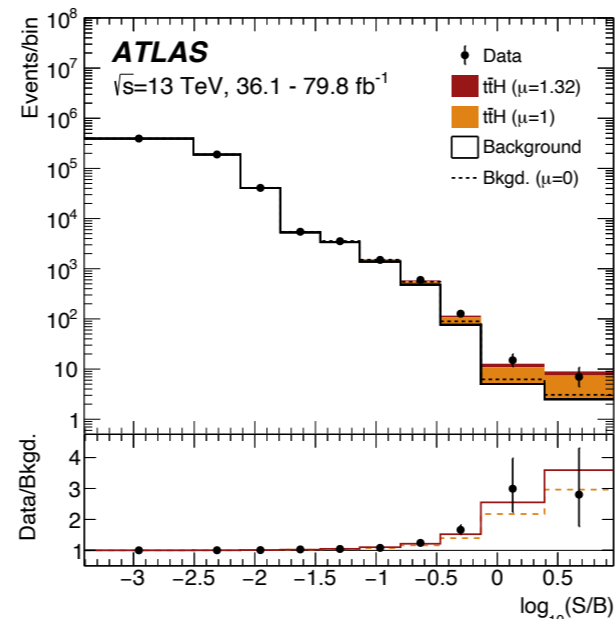

First observation in 2018

ATLAS 2510.23755

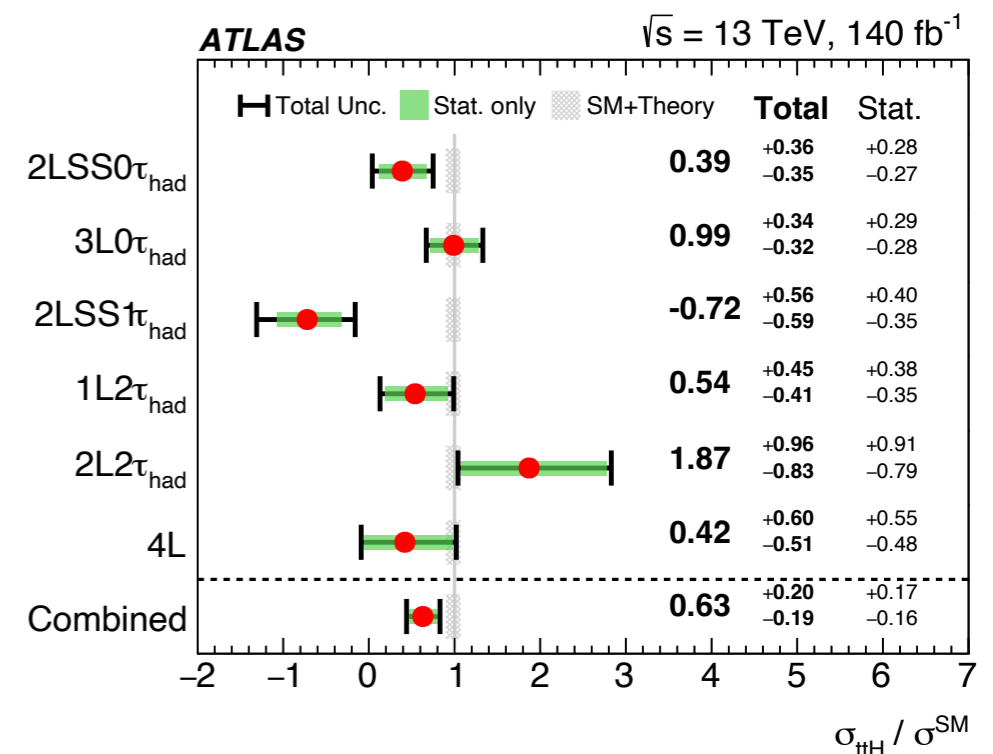
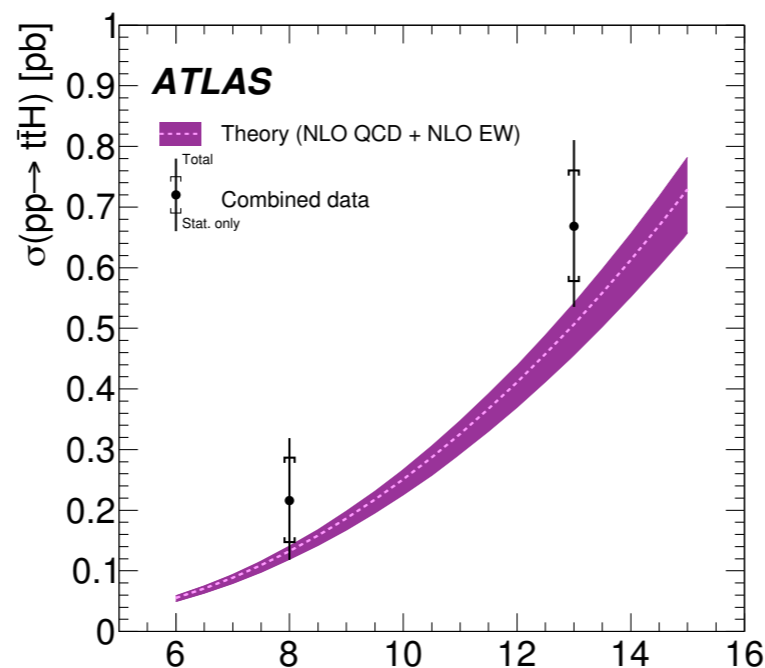
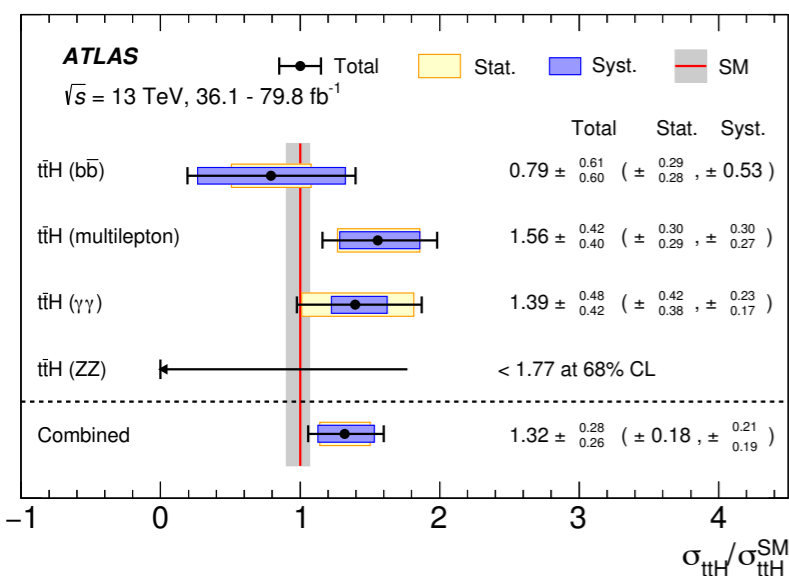

Approximate ttH at NNLO

Catani et al. 2210.04846

Two-loop pp \rightarrow ttH amplitudes still missing.

Idea: approximate with amplitudes with a soft Higgs emitted off heavy quarks

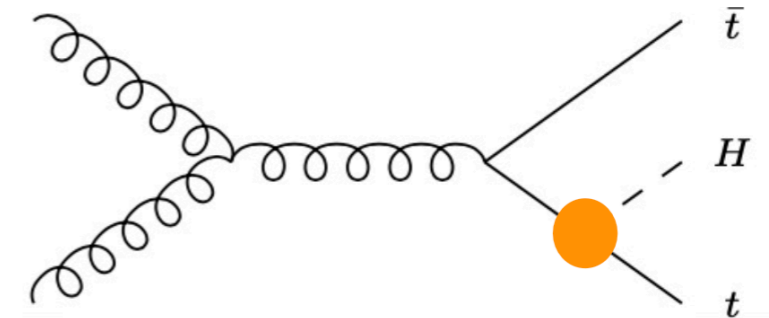

σ [fb]	$\sqrt{s} = 13$ TeV		$\sqrt{s} = 100$ TeV	
	gg	$q\bar{q}$	gg	$q\bar{q}$
σ_{LO}	261.58	129.47	23055	2323.7
$\Delta\sigma_{\text{NLO,H}}$	88.62	7.826	8205	217.0
$\Delta\sigma_{\text{NLO,H}} _{\text{soft}}$	61.98	7.413	5612	206.0
$\Delta\sigma_{\text{NNLO,H}} _{\text{soft}}$	-2.980(3)	2.622(0)	-239.4(4)	65.45(1)

Test the procedure at NLO

- ▶ approximation not that great and works better for the quark-induced channel than the gluon-induced one

Approximate ttH at NNLO

Catani et al., 2210.04846

Two-loop pp \rightarrow ttH amplitudes still missing.

Idea: approximate with amplitudes with a soft Higgs emitted off heavy quarks

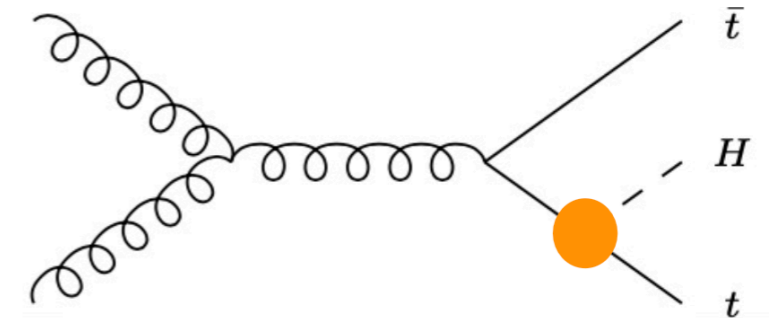

σ [fb]	$\sqrt{s} = 13$ TeV		$\sqrt{s} = 100$ TeV	
	gg	$q\bar{q}$	gg	$q\bar{q}$
σ_{LO}	261.58	129.47	23055	2323.7
$\Delta\sigma_{\text{NLO,H}}$	88.62	7.826	8205	217.0
$\Delta\sigma_{\text{NLO,H}} _{\text{soft}}$	61.98	7.413	5612	206.0
$\Delta\sigma_{\text{NNLO,H}} _{\text{soft}}$	-2.980(3)	2.622(0)	-239.4(4)	65.45(1)

Size of approx.
NNLO

- ▶ but two-loop corrections are very small (below a %)

Approximate $t\bar{t}H$ at NNLO

Catani et al., 2210.04846

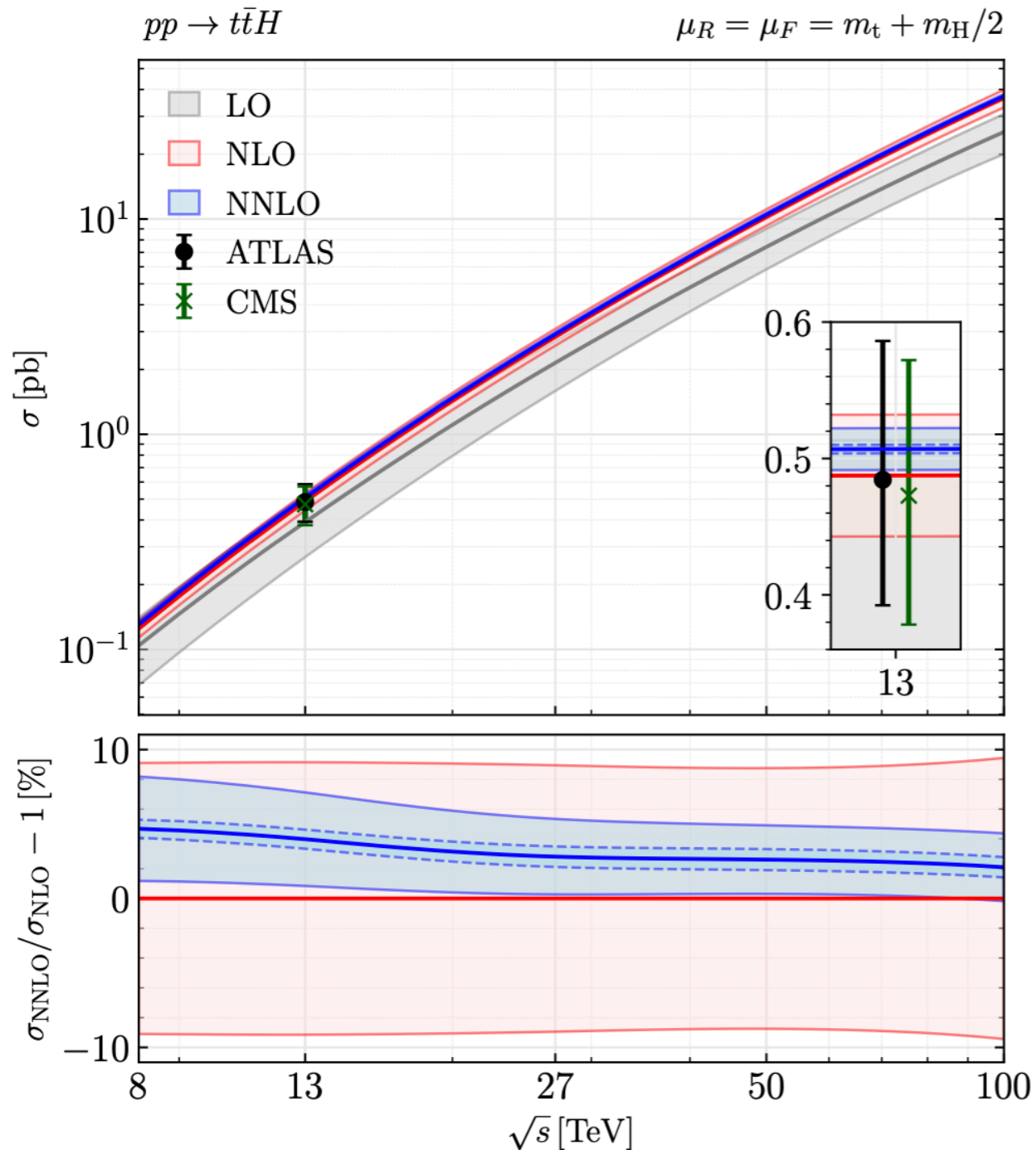

\Rightarrow estimated **uncertainty on the total cross section at the few percent level**

Interesting to validate this once full NNLO is available

ttW

ttW is crucial rare process: it is an irreducible background, limiting the sensitivity of same-sign dilepton searches and of key measurements such as ttH

Tension in data and theory NLO predictions

NNLO [15]	
Order	σ [fb]
LO QCD: $\alpha_s^2 \alpha$	420^{+106}_{-79}
NLO QCD: $+\alpha_s^3 \alpha$	622^{+79}_{-72}
NNLO QCD: $+\alpha_s^4 \alpha$	$711^{+35}_{-46} \pm 14$
NLO EWK: $+\alpha_s \alpha^3 + \alpha_s^2 \alpha^2 + \alpha^4$	$745 \pm 50 \pm 13$

+89 fb

NNLO prediction lifts tension

The best-fit value of the $t\bar{t}W$ cross-section, $\sigma(t\bar{t}W)$, is:

$$\sigma(t\bar{t}W) = 880 \pm 50 \text{ (stat.)} \pm 70 \text{ (syst.)} = 880 \pm 80 \text{ fb}$$

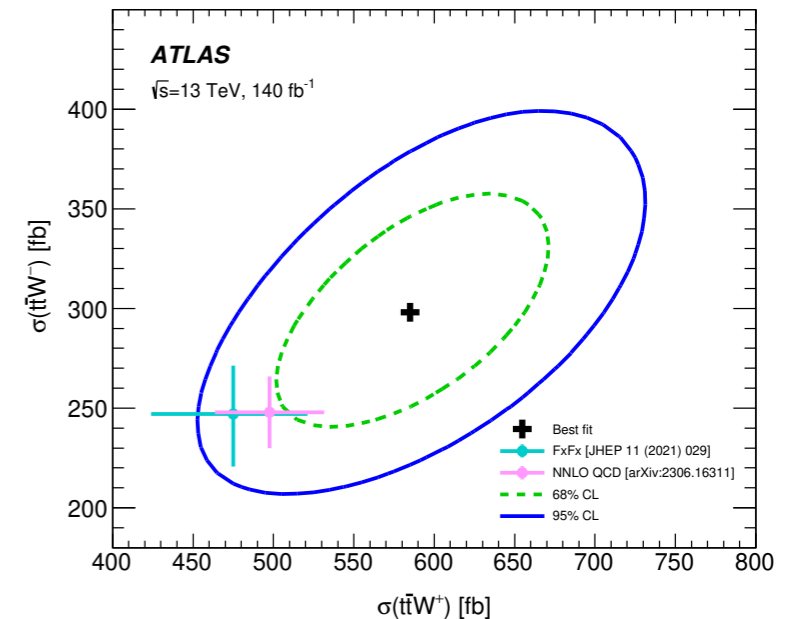
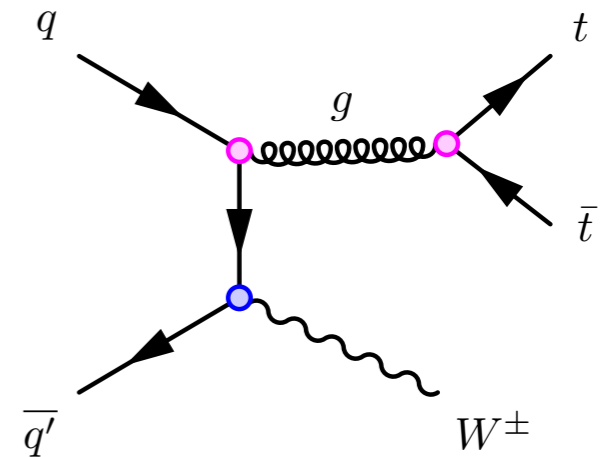

Approximate ttW at NNLO

Buonocore et al., 2306.16311

Two approximations (“soft W” and “massification”) estimate missing two-loop ttW corrections, yielding 10% accuracy at NLO and similar results at NNLO, even outside their ideal validity.

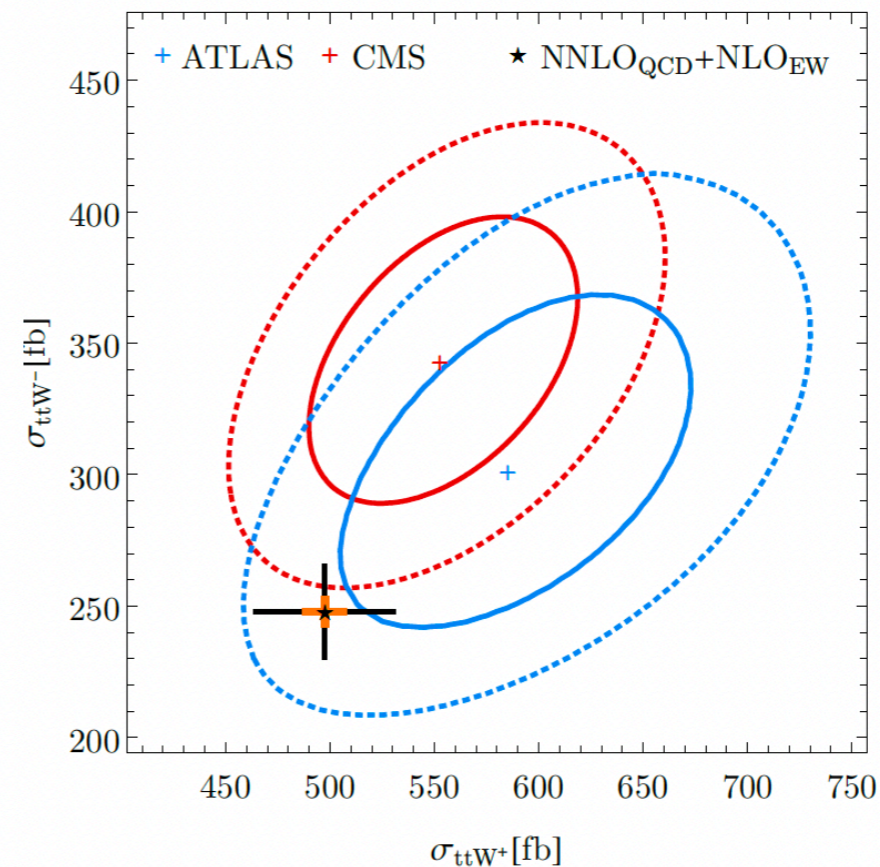
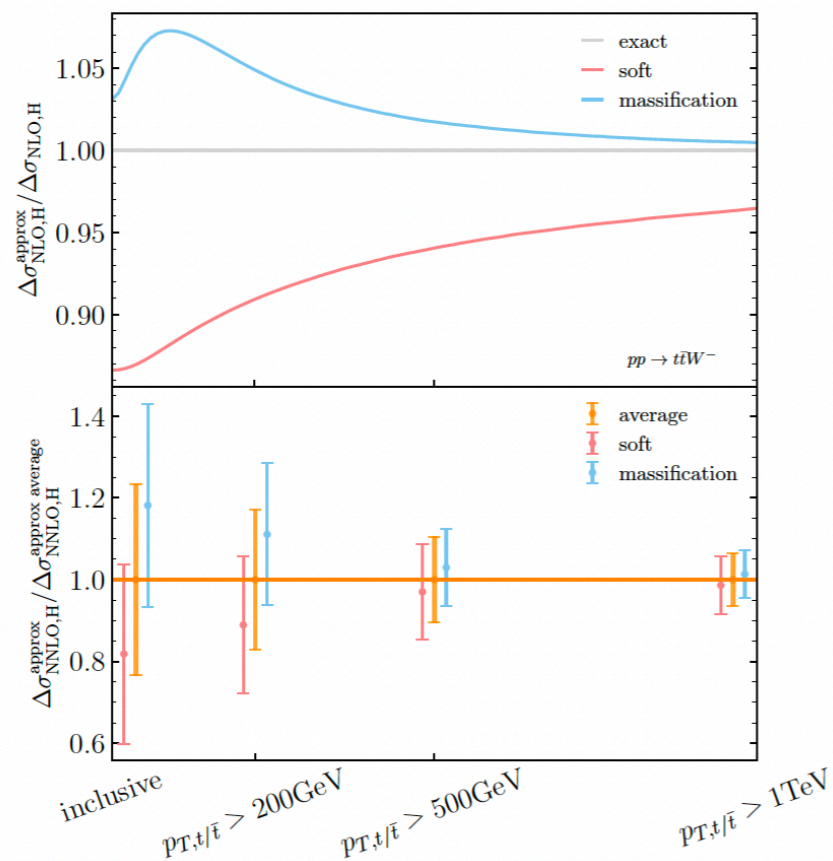

Clever approximations enable precision for key processes (ttH, ttW, ttZ, ...) crucial to constrain SM parameters (y_t , g_{ttZ} , ...).

N³LO status

DY-like (no color in final state)
2 → 1

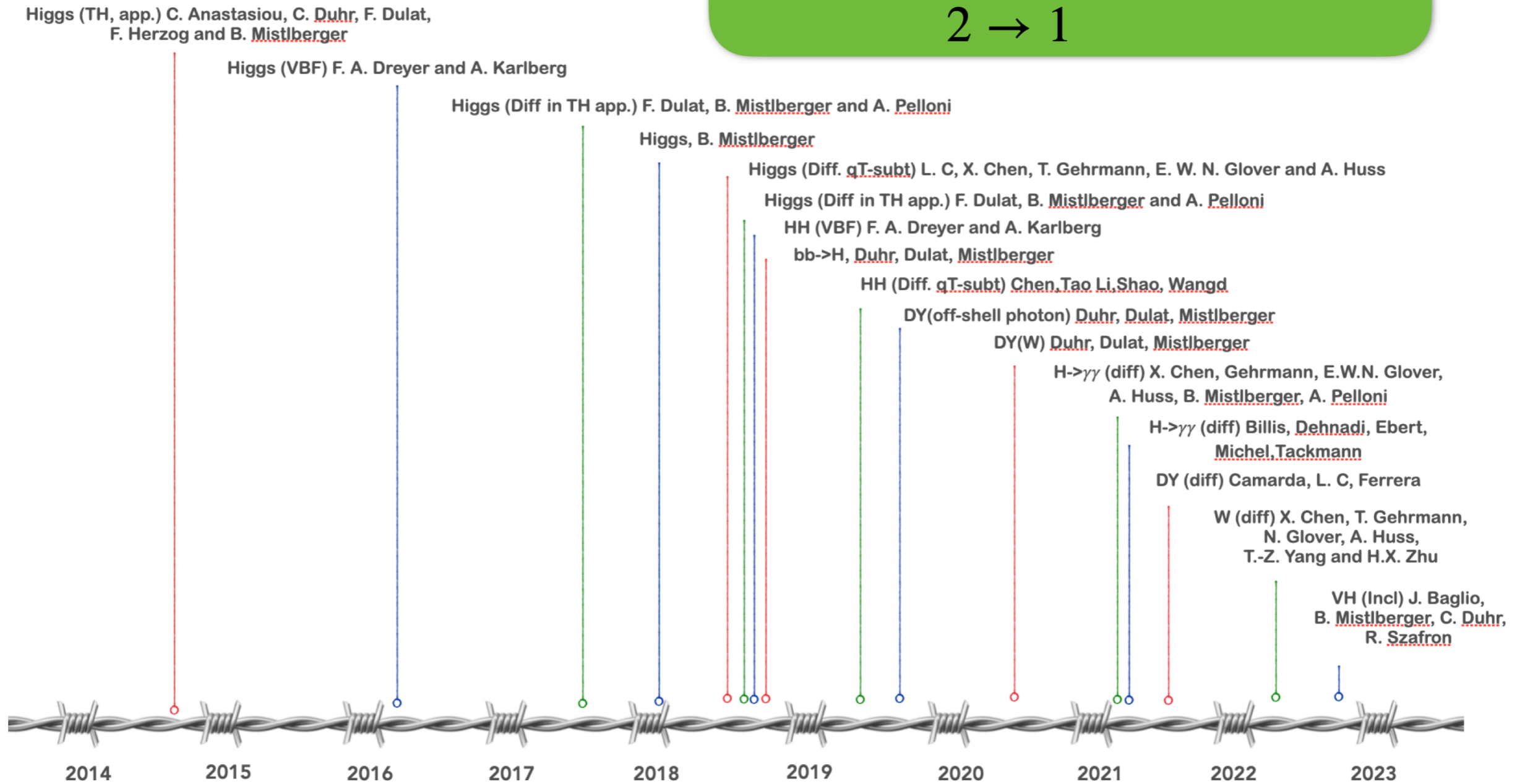

from L. Cieri

**Two examples where new theory ideas
bring in new physics opportunities**

LHC as lepton collider

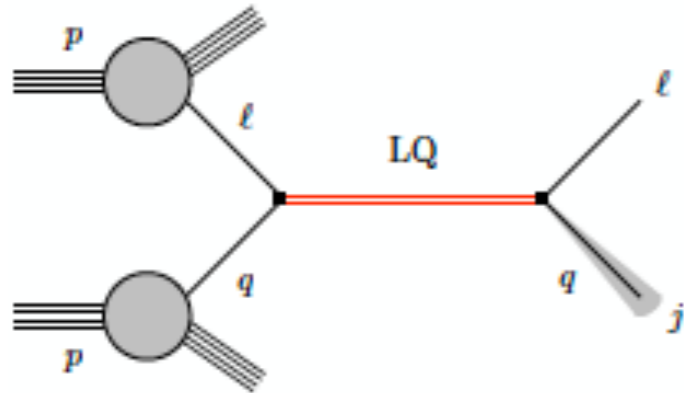

Buonocore et al., 2505.06475

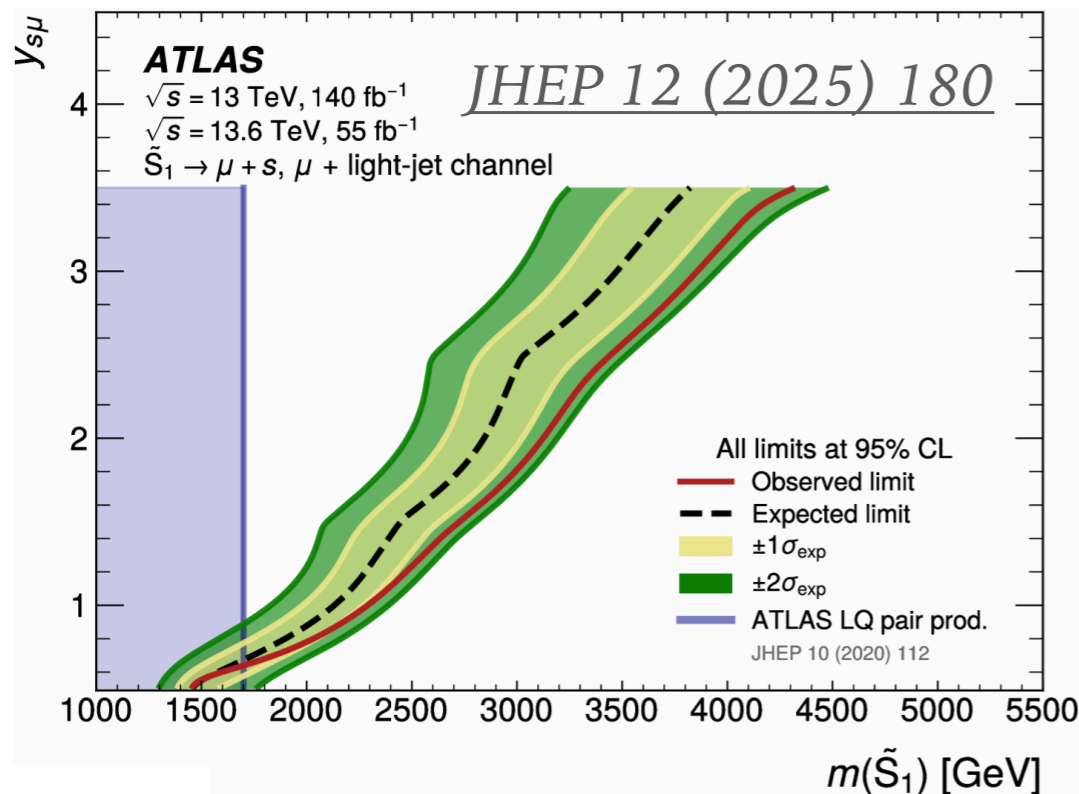
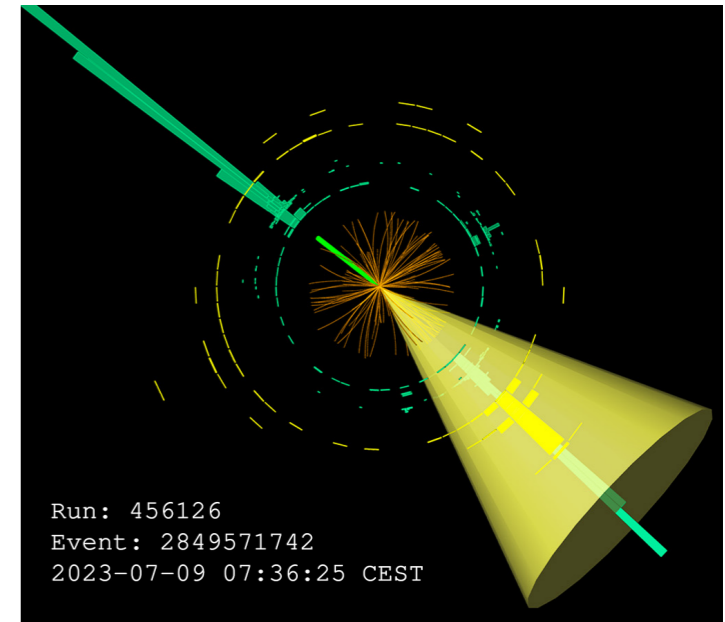
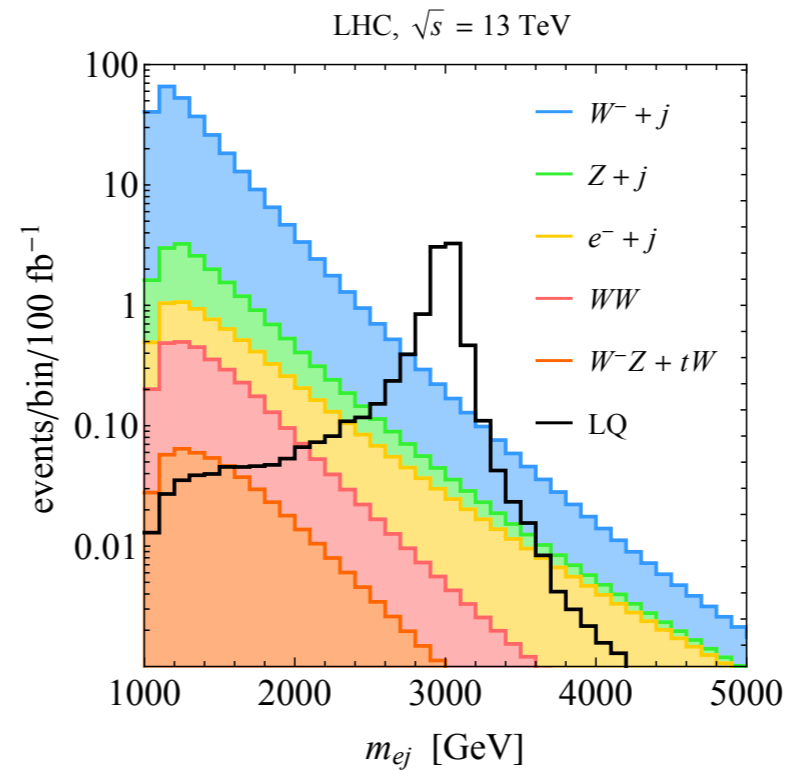

- Search for resonant (s-channel) leptoquark production
- New experimental search enabled by recent calculations of proton lepton content, resulting in lepton parton distribution functions

Strong coupling at the LHC

World average:

$$\alpha_s(M_Z) = 0.1180 \pm 0.0009$$

Strong coupling less well-known gauge coupling (error 0.8%)

Many new determinations from the LHC, one highlight

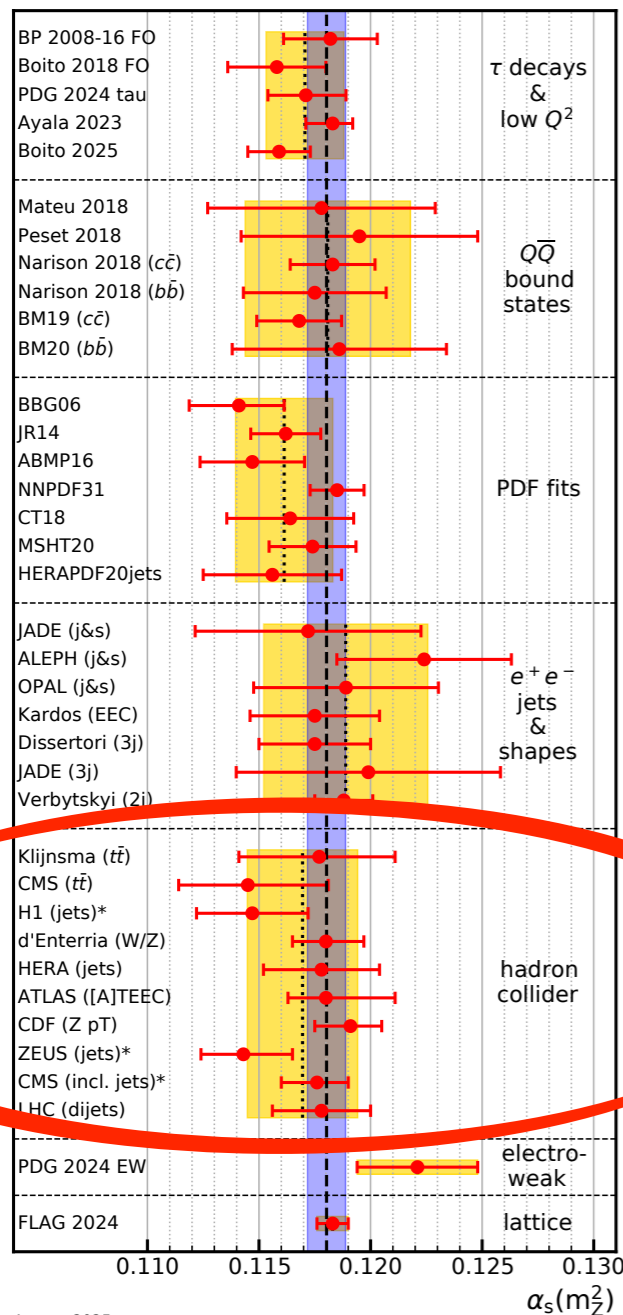

Strong coupling at the LHC

Use the fact that the shape of Drell-Yan transverse momentum spectrum at low p_T is very sensitive to $\alpha_s(M_Z)$

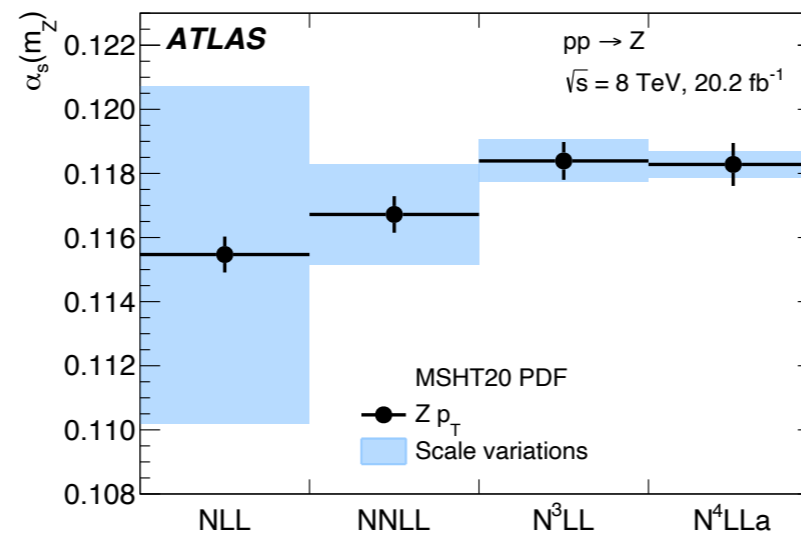
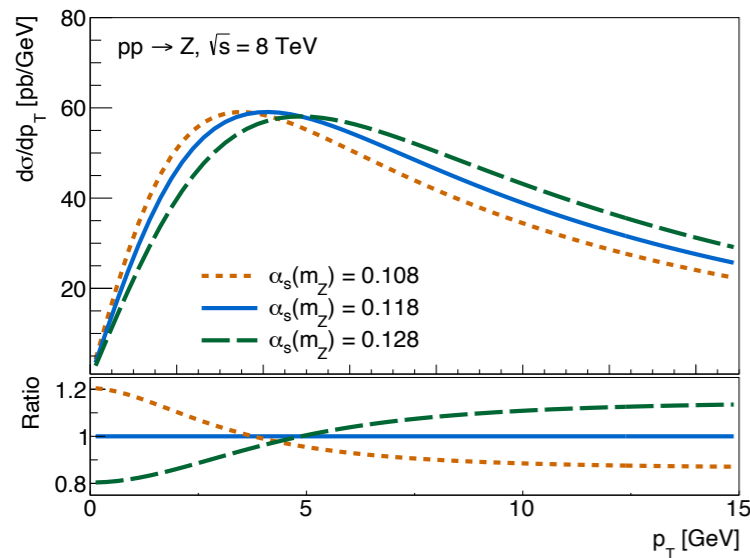
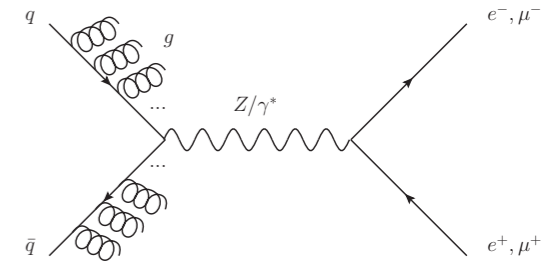

Experimental uncertainty	± 0.44
PDF uncertainty	± 0.51
Scale variation uncertainties	± 0.42
Matching to fixed order	0 -0.08
Non-perturbative model	$+0.12$ -0.20
Flavour model	$+0.40$ -0.29
QED ISR	± 0.14
N ⁴ LL approximation	± 0.04
Total	$+0.91$ -0.88

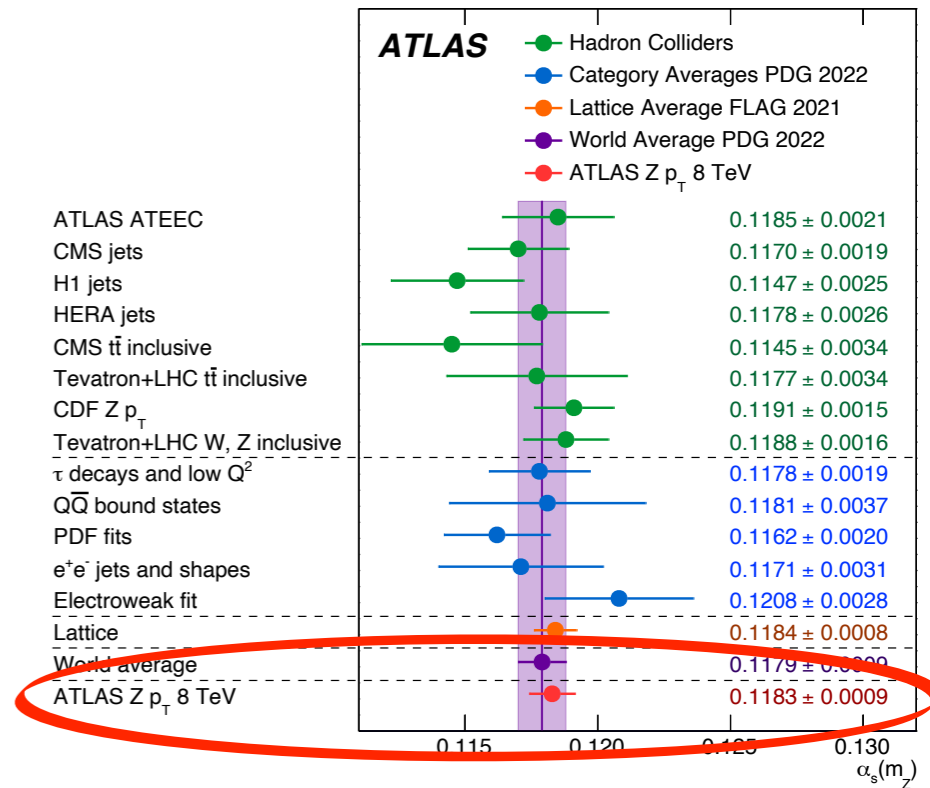

ATLAS 2309.12986

- Fully compatible with world average, with comparable error
- Accurate theory predictions indispensable for this measurement
- (Open questions regarding final uncertainty)

Road ahead

Road ahead: near future

Towards High-luminosity era (HL-LHC)

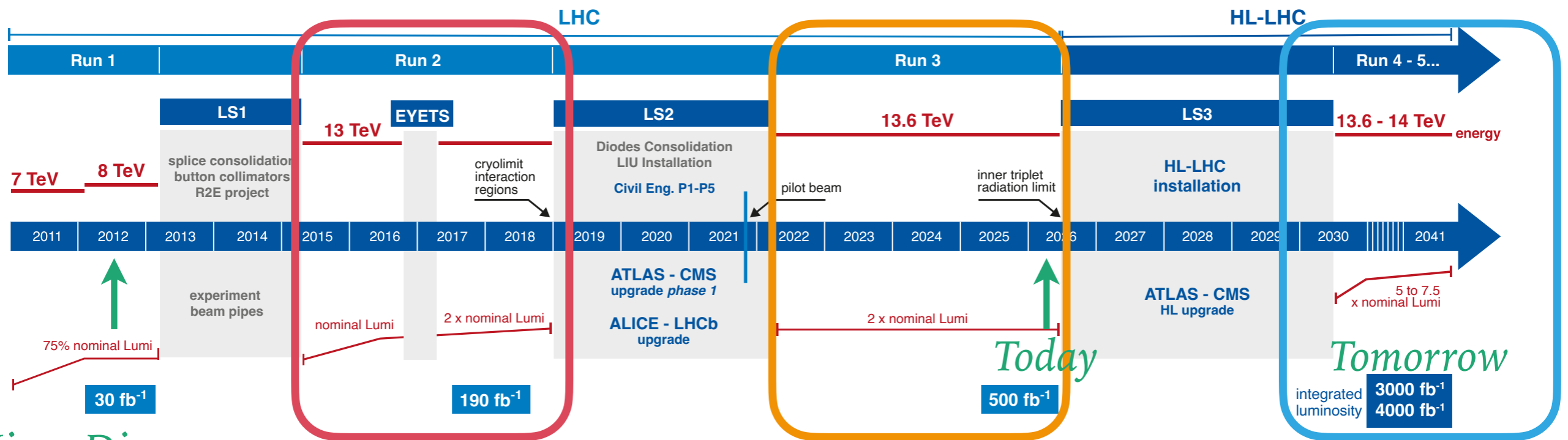

Higgs Discovery

*Most results use full Run 2:
140 fb⁻¹ @
 $\sqrt{s} = 13 \text{ TeV}$*

*Some results use partial Run 3:
up to 168 fb⁻¹ @
 $\sqrt{s} = 13.6 \text{ TeV}$*

*400 million
Higgs bosons in
ATLAS & CMS*

Road ahead: far future

Consensus building on Future Circular Collider (first e⁺e⁻, then hh):

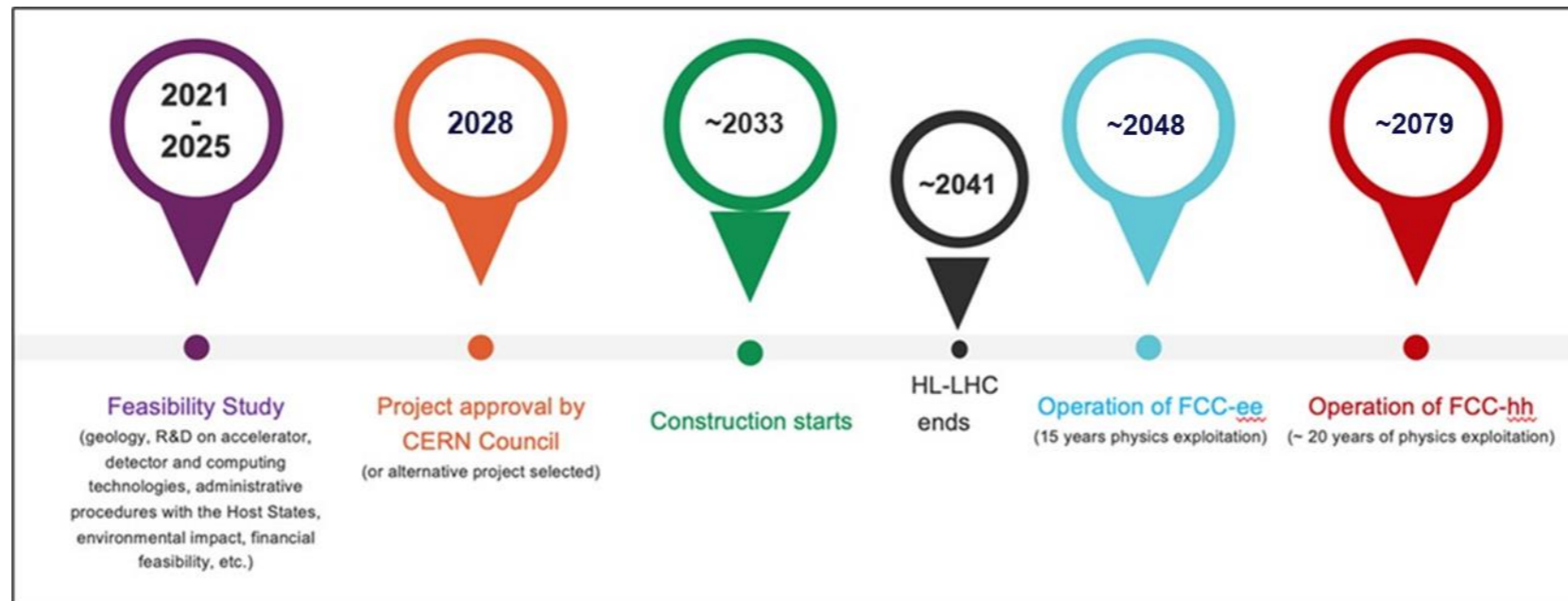

Sample current and projected total uncertainties

Observable	Current	FCC-ee
Δm_Z (keV)	2000	4 (100)
$\Delta \Gamma_Z$ (keV)	2300	4 (12)
$\delta R_\mu (\times 10^{-6})$ $R_\mu \equiv \frac{\Gamma_{had}}{\Gamma_\mu}$	1600	2.4 (2.3)
$\delta R_b (\times 10^{-6})$ $R_b \equiv \frac{\Gamma_b}{\Gamma_{had}}$	3300	1.2 (1.6)
$\Delta \sin^2 \theta_W (\times 10^6)$	130	0.4 (0.5)
$\Delta \alpha(m_Z)^{-1} (\times 10^3)$	14	0.8, 3.8
Δm_W (keV)	9900	180 (160)
$\Delta \Gamma_W$ (keV)	42000	270 (200)

From physics briefing book 2511.03883

Challenges ahead

Calculations required to match experimental uncertainty at FCC-ee:

Observable	Missing higher-order & power-suppressed corrections
Hadronic Z width	$\mathcal{O}(\alpha_s^5)$, $\mathcal{O}(\alpha_s^6)$, $\mathcal{O}(\alpha^3)$, $\mathcal{O}(\alpha_s \alpha^3)$, $\mathcal{O}(\alpha_s^2 \alpha^2)$
Hadronic W width	$\mathcal{O}(\alpha_s^5)$, $\mathcal{O}(\alpha^2)$, $\mathcal{O}(\alpha_s^2 \alpha)$
Hadronic τ width	$\mathcal{O}(\alpha_s^5)$
Hadronic event shapes (Z , W , H decays)	N^3 LO differential, $N^{3,4}$ LL resummation, power corrections
Inclusive jet rates	3-jet cross-sections at N^3 LO, 4-jets at N^2 LO, 5-jets at NLO
Lattice QCD results (α_s extr.; quark masses m_c, m_b)	$\mathcal{O}(\alpha_s^6)$ β -function; $\mathcal{O}(\alpha_s^5)$ heavy quark decoupling; $\mathcal{O}(\alpha_s^4)$ static potential $\mathcal{O}(\alpha_s^3)$ lattice perturbation theory matching (lattice coupling to $\alpha_s^{\overline{MS}}$ etc.)
$\sigma(e^+e^- \rightarrow W^+W^-)$ vs. \sqrt{s}	EW N^2 LO: $\mathcal{O}(\alpha^2)$, Mixed EW-QCD: $\mathcal{O}(\alpha_s \alpha^2)$, $\mathcal{O}(\alpha_s^2 \alpha)$
$\sigma(e^+e^- \rightarrow t\bar{t})$ vs. \sqrt{s}	NRQCD: $\mathcal{O}(\alpha_s^5)$, Non-resonant: $\mathcal{O}(\alpha_s^5)$, $\mathcal{O}(\alpha_s^3)$ differential; QED: $\mathcal{O}(\alpha^3)$ at NNLL
$H \rightarrow b\bar{b}$ width	N^4 LO ($m_b \neq 0$); N^4 LO differential ($m_b = 0$)
$H \rightarrow gg$ width	N^5 LO (heavy-top limit), N^4 LO ($m_t \neq 0$); N^4 LO differential, N^3 LO differential ($m_t \neq 0$)
MC simulations for $e^+e^- \rightarrow X$ processes	$N^{2,3}$ LO matched to $N^{2,3}$ LL PS. Per mille control of non-pQCD effects (hadronization, CR, ...)
$ep \rightarrow$ hadrons (PDF and α_s determ.)	$N^{3,4}$ LO evolution equations and inclusive cross-sections
$ep \rightarrow$ jets (α_s determ.)	N^3 LO cross-sections

From physics briefing book 2511.03883

The success of this program hinges on a step change in theoretical precision, including ultra-precise perturbative QCD and electroweak calculations, non-perturbative dynamics and next-generation Monte Carlo tools. It requires a dedicated community effort.

Conclusion

Progress in perturbative calculations beyond expectations
⇒ remarkable success of theorists

- Progress not due to cranking old machinery but driven by new ideas and developments of new methods
- Strong complementary between numerical and analytical methods
- Development of clever and robust approximations key to meet precision goals
- [Many other aspects not covered in this talk, e.g. all orders resummation, parton showers, non-perturbative effects...]

Many calculations eagerly awaited and in sight in the next five years

Perturbative QCD well on track to keep up with experimental precision at the HL-LHC (precision at FCC-ee requires yet a dedicated effort)